



Shaping the
connected world

2024

**Mobile
communication**

In-building solutions
and antenna line products





Shaping the
connected world

**We are your
specialist for
reliable, high
quality and
innovative
communication
technologies.**



ESB is a global company Customer-focused with headquarters in Spain (Valencia) which manufactures and develops Mobile Communication solutions in different areas like macro, micro, indoor coverage, smallcells and camouflage antenna Solutions for Communication Service Providers around the world.

Our vision

We trust in the efficient and sustainable telecom infrastructure as a primary driver in the international integration

Mission

Communication technologies play an important role in the process of evolution.

They connect people and enable the world to be connected. ESB pursues an effective and responsible connection of the worlds' technologies. Demand of these technologies is constantly rising, as well as global data consumption. With more than 40 years experience, we are capable of meeting the most complex requirements and challenges.

"It is our mission to shape a connected world, continue to build it and improve its efficiency using innovative and sustainable technologies"

Our near future depends on new technologies. Due to our strong roots and experience, we will fight daily to achieve this environmental friendly connected world.

Esb mobile communication portfolio offers high-end Wireless products for all frequency bands and global standards, we are constantly evolving our portfolio to meet the market demand and in close cooperation with our customers and sales network, from the proof of concept to massive production.

Our Values

ESB develops and sales telecom products on a global market. Working globally with the automotive and telecom industry brings the responsibility of working towards social and economic development and sustainability, as well as conducting business responsibly.

We work actively in our basic values: Innovation, cooperation, long-term approach and reduction of environmental impact.

Innovation: every day we pursue innovation in all we do. we focus on research, development and innovation (R & D & I). These 3 factors are the basis of our growth and our main difference compared to our competitors.

Cooperation. Working on product development gives us the opportunity to collaborate with any kind of company. We work effusively to maintain respectful and positive relations with all of our partners as well as suppliers, clients and everyone else whom we work with.

Long-Term approach. Developing products implies committing to long-term approaches with our partners and major investors. Having a long-term mind-set with regard to sustainability and management secures customer and owner value over time.

Environmental friendly. ESB works on daily basis to reduce visual impact of the telecommunication sector in our world. Therefore, product development moves towards the integration of the antenna with the environment.

Quality Policy. Quality is the best argument when it comes to competing on the market and represents a guarantee for the continuity and the future of any company.





Content



● In-building solutions

- Indoor Antennas **_10**
- Low PIM Splitters **_30**
- Low PIM Directional Couplers **_40**
- RF Tappers **_48**
- Standard Attenuators **_50**
- Low PIM Attenuators **_60**
- Low PIM Loads **_66**

● Antenna line products

- Hybrid Combiners **_76**
- Special Antennas **_86**
- Smallcell Antennas **_100**
- Multi-band Combiners **_118**
- Trisector and Cannister antennas **_142**



In-building solutions



We offer a broad product portfolio for in-building solutions consisting of antennas, splitters, couplers, combiners, low PIM attenuators, low PIM loads and many more components for our customers with the latest and most reliable technology available on the market for current and future mobile networks.

● **In-building solutions**

- Indoor Antennas **_10**
- Low PIM Splitters **_30**
- Low PIM Directional Couplers **_40**
- RF Tappers **_48**
- Standard Attenuators **_50**
- Low PIM Attenuators **_60**
- Low PIM Loads **_66**

Indoor antennas

ESB portfolio offers a wide variety of Low intermodulation (PIM3) indoor omni and directional panel antennas for each application. Customer can select from 1 port antenna up to 4 port antennas with different connector (4.3-10 & N) for the most demanding scenarios. All antennas have passed a comprehensive quality control check.

Part Number	Description	Page
78711019v01	1-Port Omni 698-960 (SISO)/1425-4000 (SISO) N	12
78712019v01	1-Port Omni 698-960 (SISO)/1425-4000 (SISO) 4.3-10	12
78711020	2-Port Omni 698-960 (MIMO)/1710-2700 (MIMO) N	13
78712020	2-Port Omni 698-960 (MIMO)/1710-2700 (MIMO) 4.3-10	13
78711030	2-Port Omni 698-960 (MIMO)/1710-4000 (MIMO) N	14
78712030	2-Port Omni 698-960 (MIMO)/1710-4000 (MIMO) 4.3-10	14
78712323	1-Port Directional 698-960 (SISO)/1425-4000 (SISO) 4.3-10	15
78711323	1-Port Directional 698-960 (SISO)/1425-4000 (SISO) N	15
78712031	1-Port Omni 698-4000 (SISO) 4.3-10	16
78712033	1-Port Card Omni 698-4000 (SISO) 4.3-10	17
78712038	1-Port Slim Omni 380-4000 (SISO) 4.3-10	18
78712035	1-Port Slim Omni 698-6000 (SISO) 4.3-10	19
78712311	2-Port Directional 698-960 (MIMO)/1710-2700 (MIMO) 4.3-10	20
78712330	2-Port Directional 698-960 (MIMO)/1710-4000 (MIMO) 4.3-10	21
78712032	2-Port Card Omni 617-4200 (MIMO) 4.3-10	22
78712036	2-Port Ultra-Thin Omni 698-6000 (MIMO) 4.3-10	23
78712041	1-Port Omni 380-6000 (SISO) 4.3-10	24
78712043	1-Port Omni Cubical 698-4000 (SISO) 4.3-10	25
78712045	1-Port Omni Cylindrical 698-4000 (SISO) 4.3-10	25
78713160	4-Port Omni MIMO 698-4000MHz 4.3-10	26
78733160	4-Port Omni MIMO 698-4000MHz N	26
78715160	4-Port Ultra Thin Omni MIMO 698-6000MHz 4.3-10	27
78713130	4-port directional MIMO 698-4000MHz 4.3-10	28
78733130	4-port directional MIMO 698-4000MHz N	28

7871x019v01

Indoor
Omnidirectional Antenna
V-Pol 1-port 2/5dBi
698-4200

Omni Indoor
698-4200 2/5dBi (Dome)

Type	78712019v01		78711019v01	
	Frequency (MHz)	698-805	806-960	1425-2700
Gain (dBi)	2.0	2.0	5.0	5.5
VSWR	≤ 2.0	≤ 1.8	≤ 1.5	≤ 1.5
Polarization	Vertical			
PIM3 (dBc, @2x43dBm)	≤ -153			
Horizontal Beamwidth (°)	360			
Vertical Beamwidth (°)	85	80	54	28
Input Impedance (ohm)	50			
Max. Input Power (W)	50			
Lightning Protection	DC Grounded			
Connector	1 x 4.3-10 Female		1 x N Female	
Dimension (mm)	Ø186 x 86			
Weight (kgs)	Approx. 0.25			
Reflector Material	Aluminum			
Radome Material	ABS (UV Stabilized)			
Operating Temperature (°C)	-40 to +65			

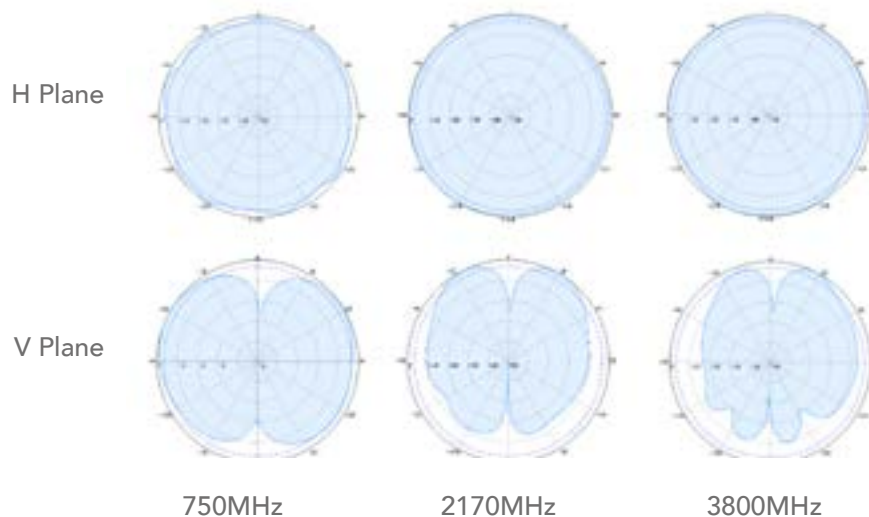

7871x020

Indoor
Omnidirectional Antenna
H/V-Pol 2-port 3/5dBi
698-2700

Omni Indoor
698-2700 3/5dBi

Type	78712020	78711020
Frequency (MHz)	698-960	1710-2700
Gain (dBi)	3.0	4.5
VSWR	≤ 1.8	≤ 1.7
Polarization	H-V	
Isolation (dB)	≥ 19	≥ 23
PIM3 (dBc, @2x43dBm)	≤ -150	
Horizontal Beamwidth (°)	360	
Vertical Beamwidth (°)	90	46
Input Impedance (ohm)	50	
Max. Input Power (W)	50	
Lightning Protection	DC Grounded	
Connector	2 x 4.3-10 Female	2 x N Female
Dimension (mm)	Ø215 x 47	
Weight (kgs)	Approx. 0.45	
Reflector Material	Copper and PCB	
Radome Material	ABS (UV Stabilized)	
Operating Temperature (°C)	-40 to +65	

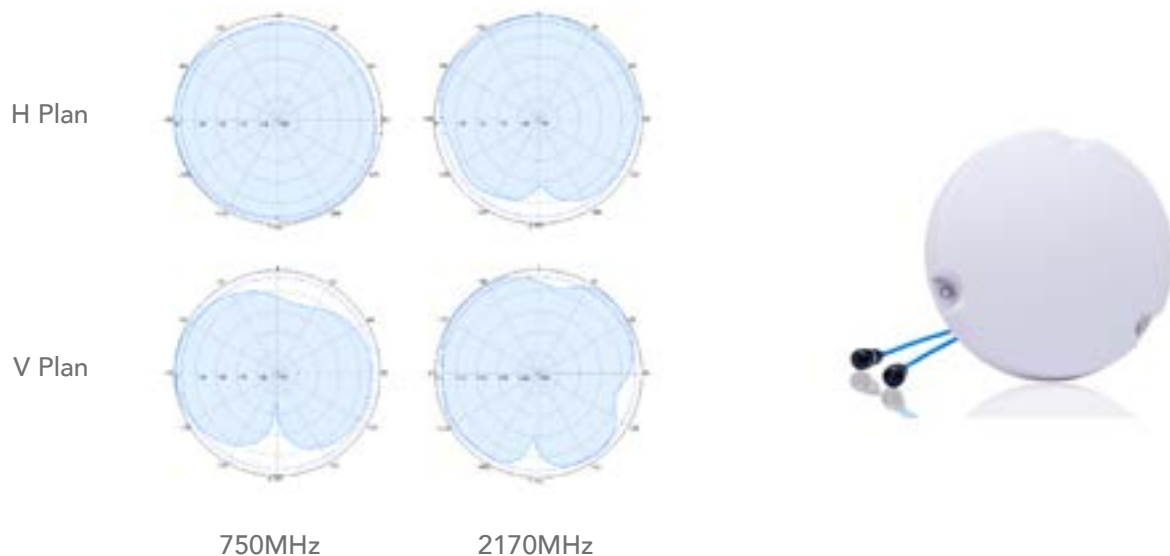

7871x030

Indoor
Omnidirectional Antenna
H/V-Pol 2-port 3/5dBi
698-4000

Omni Indoor 698-4000 3/5dBi

Type	78712030		78711030	
	Frequency (MHz)	698-805	806-960	1425-2700
Gain (dBi)	2.5	3.5	4.5	5.0
VSWR	≤ 2.0	≤ 1.8	≤ 1.8	≤ 1.8
Polarization	H-V			
Isolation (dB)	≥ 19		≥ 23	
PIM3 (dBc, @2x43dBm)	≤ -153			
Horizontal Beamwidth (°)	360			
Vertical Beamwidth (°)	95	90	46	38
Input Impedance (ohm)	50			
Max. Input Power (W)	50			
Lightning Protection	DC Grounded			
Connector	2 x 4.3-10 Female		2 x N Female	
Dimension (mm)	Ø215 x 47			
Weight (kgs)	Approx. 0.45			
Reflector Material	Aluminum			
Radome Material	ABS (UV Stabilized)			
Operating Temperature (°C)	-40 to +65			

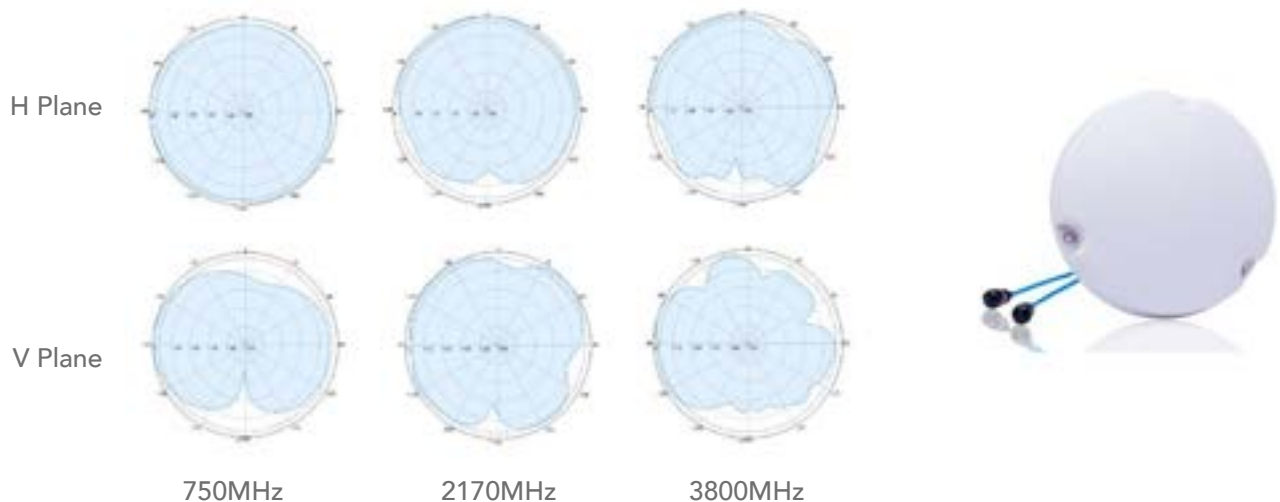

7871x323

Indoor
Directional Panel Antenna
VPol 1-port 6/8dBi
698-4000MHz

Panel Indoor 698-4000MHz 6/8dBi

Type	78712323		78711323	
	Frequency (MHz)	698-806	806-960	1425-2700
Gain (dBi)	5.5	6.5	8.0	7.0
VSWR	≤ 2.0	≤ 2.0	≤ 1.8	≤ 1.8
Polarization	Vertical			
PIM3 (dBc, @2x43dBm)	≤ -153			
Front-to-Back Ratio (dB)	≤ 9	≤ 10	≤ 15	≤ 11
Horizontal Beamwidth (°)	100	85	65	50
Vertical Beamwidth (°)	90	82	60	45
Input Impedance (ohm)	50			
Max. Input Power (W)	50			
Lightning Protection	All metal parts of the antenna and mounting kit are DC grounded. Inner conductor is not DC grounded			
Connector	4.3-10 Female		N Female	
Dimension (mm)	180 x 158 x 60			
Weight (kgs)	Approx. 0.40			
Reflector Material	Aluminum			
Radome Material	ABS (UV Stabilized with RAL 9003)			
Operating Temperature (°C)	-40 to +65			

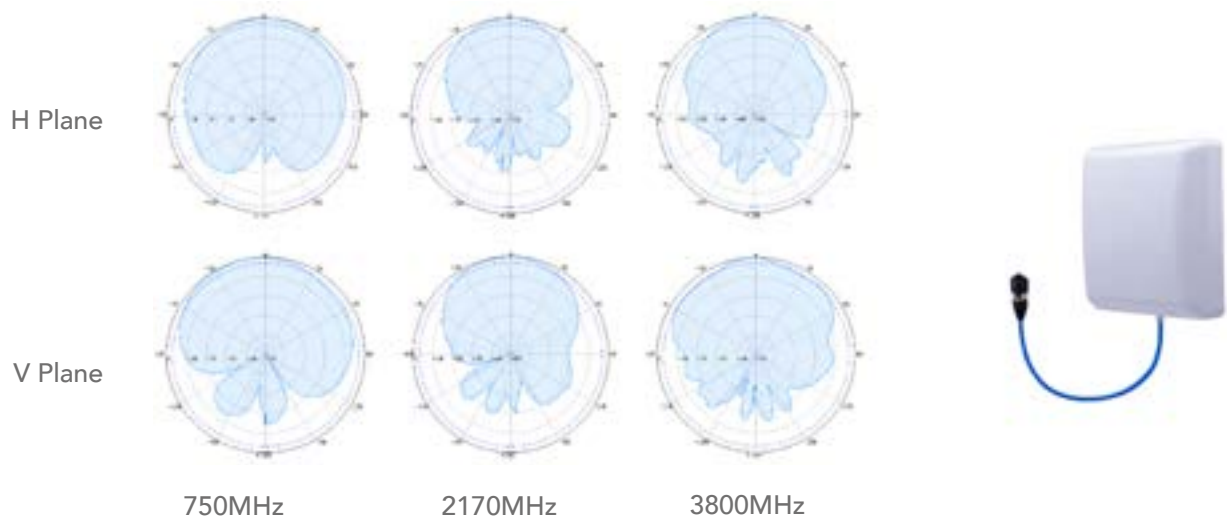

78712031

Indoor
Omnidirectional Antenna
V-Pol 1-port 2/4dBi
698-4000

Omni Indoor 698-4000 2/4dBi

Type	78712031			
Frequency (MHz)	698-805	806-960	1425-2700	3300-4000
Gain (dBi)	1.5	2.0	3.0	4.0
VSWR	≤ 2.0	≤ 2.0	≤ 1.5	≤ 1.5
Polarization	Vertical			
PIM3 (dBc, @2x43dBm)	≤ -153			
Horizontal Beamwidth (°)	360			
Vertical Beamwidth (°)	95	80	38	32
Input Impedance (ohm)	50			
Max. Input Power (W)	50			
Lightning Protection	DC Grounded			
Connector	4.3-10 Female			
Dimension (mm)	Ø204 x 125			
Weight (kgs)	Approx. 0.40			
Reflector Material	Aluminum			
Radome Material	ABS (UV Stabilized)			
Operating Temperature (°C)	-40 to +65			

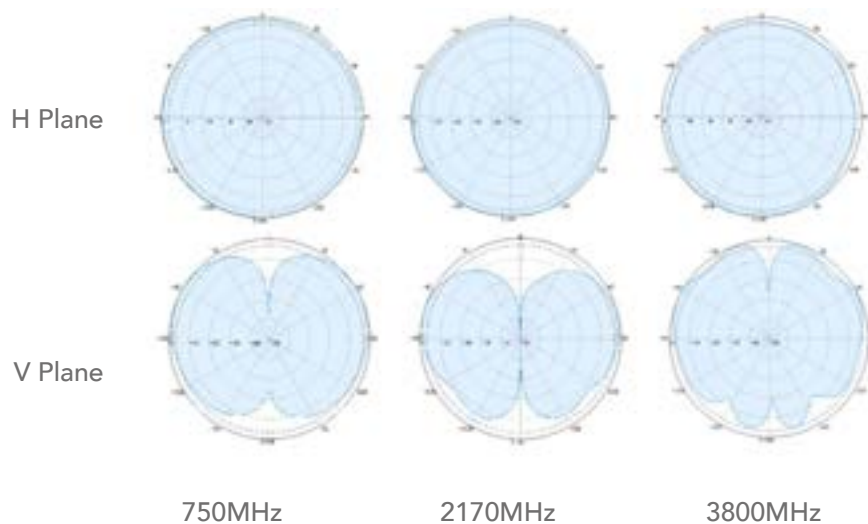

78712033

Indoor
Omnidirectional Antenna
H-Pol 1-port 3/5dBi
698-4000

**Omni Indoor
698-4000 3/5dBi (Rectangular Card)**

Type	78712033				
Frequency (MHz)	698-960	1425-1690	1690-2170	2170-2700	3300-4000
Gain (dBi)	3.0	3.5	4.0	5.0	4.0
VSWR	≤ 2.0	≤ 2.0	≤ 1.8	≤ 1.8	≤ 1.8
Polarization	Horizontal				
PIM3 (dBc, @2x43dBm)	≤ -153				
Horizontal Beamwidth (°)	360				
Vertical Beamwidth (°)	118	85	75	63	70
Input Impedance (ohm)	50				
Max. Input Power (W)	50				
Lightning Protection	DC Grounded				
Connector	1 x 4.3-10 Female				
Dimension (mm)	180 x 110 x 7				
Weight (kgs)	Approx. 0.2				
Reflector Material	RF PCB				
Radome Material	ABS (UV Stabilized)				
Operating Temperature (°C)	-40 to +65				

A)4WN51115907YR/4WO51115907YR

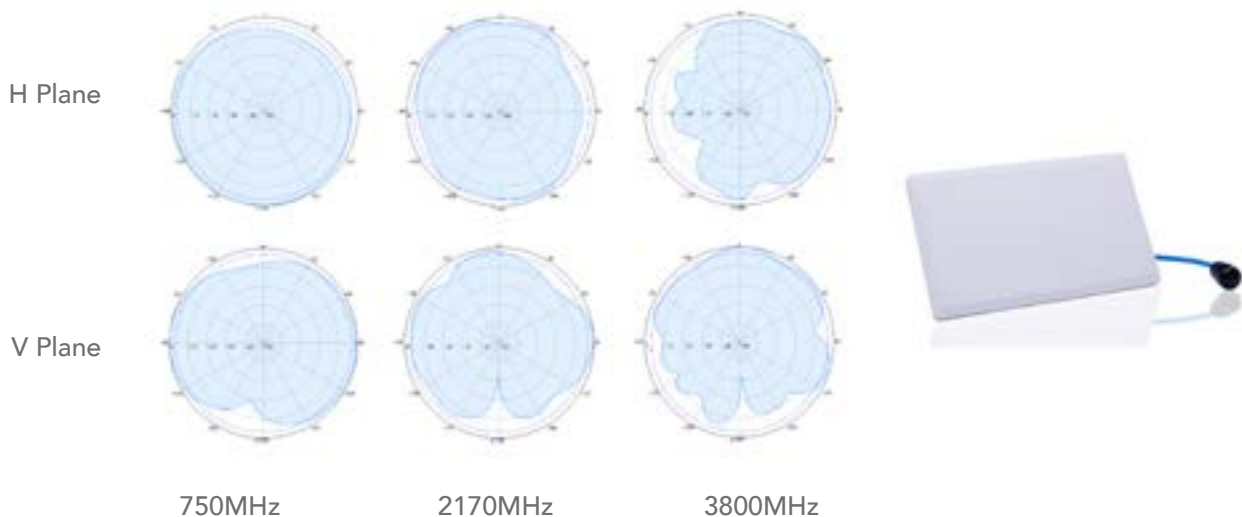

78712038

Indoor
Omni Antenna Thin
H-Pol 1-port 2/5dBi
380-4000Mhz

Omni Indoor 380-4000 2/5dBi (Thin-plate)

Type	78712038			
Frequency (MHz)	380-520	698-960	1710-2700	3300-4000
Gain (dBi)	2.0 ±1	2.0 ±1	4.0 ±1	4.5 ±1
VSWR	≤ 2.0	≤ 2.0	≤ 1.8	≤ 1.8
Polarization	Vertical			
PIM3 (dBc, @2x43dBm)	≤-153			
Horizontal Beamwidth (°)	360			
Vertical Beamwidth (°)	120	85	76	58
Input Impedance (ohm)	50			
Max. Input Power (W)	50			
Lightning Protection	DC Grounded			
Connector	1 x 4.3-10 Female			
Dimension (mm)	Ø280 x 19			
Weight (kgs)	Approx. 0.5			
Radome Material	ABS (UV Stabilized)			
Operating Temperature (°C)	-40 to +65			



78712035

Indoor
Omnidirectional Antenna
H-Pol 1-port 3/5dBi
698-4000

Omni Indoor
698-4000 3/5dBi (Flat)

Type	78712035				
Frequency (MHz)	698-960	1425-1690	1690-2170	2170-2700	3300-4000
Gain (dBi)	2.5	3.5	4.0	5.0	4.0
VSWR	≤ 2.0	≤ 2.0	≤ 1.8	≤ 1.8	≤ 1.8
Polarization	Horizontal				
PIM3 (dBc, @2x43dBm)	≤ -153				
Horizontal Beamwidth (°)	360				
Vertical Beamwidth (°)	116	90	78	70	65
Input Impedance (ohm)	50				
Max. Input Power (W)	50				
Lightning Protection	DC Grounded				
Connector	1 x 4.3-10 female				
Dimension (mm)	Ø190 x 7.3				
Weight (kgs)	Approx. 0.2				
Reflector Material	RF PCB				
Radome Material	ABS (UV Stabilized)				
Operating Temperature (°C)	-40 to +65				

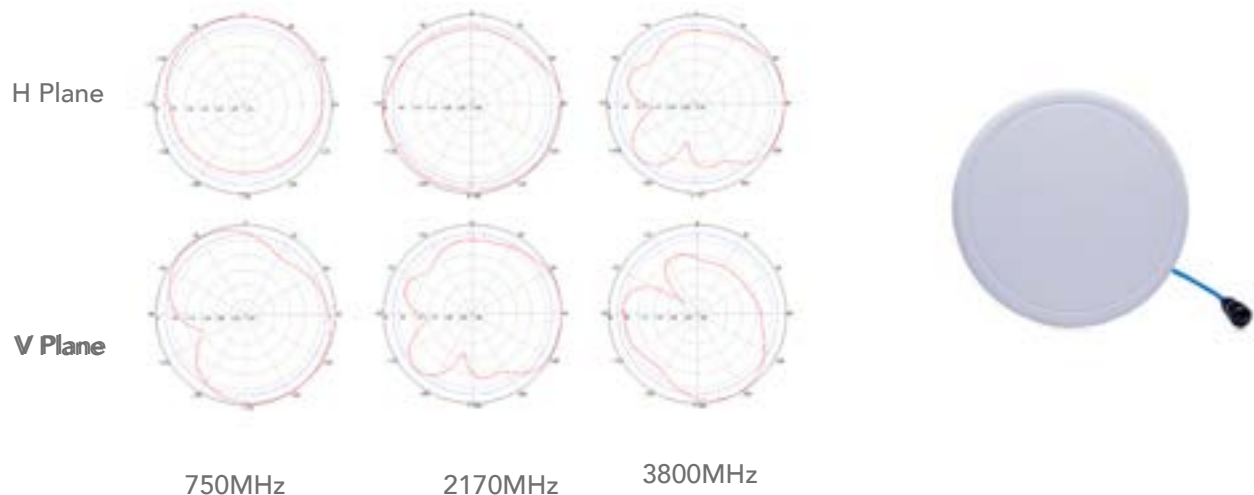

7871x311

Indoor
Panel Directional Antenna
H/V-Pol 2-port 6/9dBi
698-2700

Panel Indoor
698-2700 7/9dBi

Type	78712311		78711311	
	Frequency (MHz)	698-805	806-960	1690-2170
Gain (dBi)	6.5	7.0	8.5	9.0
VSWR	≤ 1.8		≤ 1.7	
Polarization	±45°			
PIM3 (dBc, @2x43dBm)	≤ -150			
Isolation (dB)	≤ 20		≤ 23	
Horizontal Beamwidth (°)	78	73	65	60
Vertical Beamwidth (°)	70	62	58	55
Input Impedance (ohm)	50			
Max. Input Power (W)	50			
Lightning Protection	DC Grounded			
Connector	2 x 4.3-10 Female		2 x N Female	
Dimension (mm)	315 x 195 x 68			
Weight (kgs)	Approx. 0.7			
Reflector Material	Copper and PCB			
Radome Material	ABS (UV Stabilized)			
Operating Temperature (°C)	-40 to +65			



78712330

Indoor
Panel Directional Antenna
H/H-Pol 2-port 6/9dBi
698-4000

Panel Indoor
698-4000 6/9dBi

Type	78712330		
Frequency (MHz)	698-960	1425-2700	3300-4000
Gain (dBi)	5.5	8.5	7.0
VSWR	≤ 2.0	≤ 1.8	≤ 2.0
Polarization	H-V		
PIM3 (dBc, @2x43dBm)	≤ -153		
Isolation (dB)	≥ 12	≥ 20	≥ 24
Front-to-Back Ratio (dB)	≥ 7	≥ 13	≥ 10
Horizontal Beamwidth (°)	90	65	45
Vertical Beamwidth (°)	78	60	38
Input Impedance (ohm)	50		
Max. Input Power (W)	50		
Lightning Protection	DC Grounded		
Connector	2 x 4.3-10 Female		
Dimension (mm)	315 x 195 x 68		
Weight (kgs)	Approx. 0.65		
Reflector Material	Aluminum and PCB		
Radome Material	ABS (UV Stabilized)		
Operating Temperature (°C)	-40 to +65		

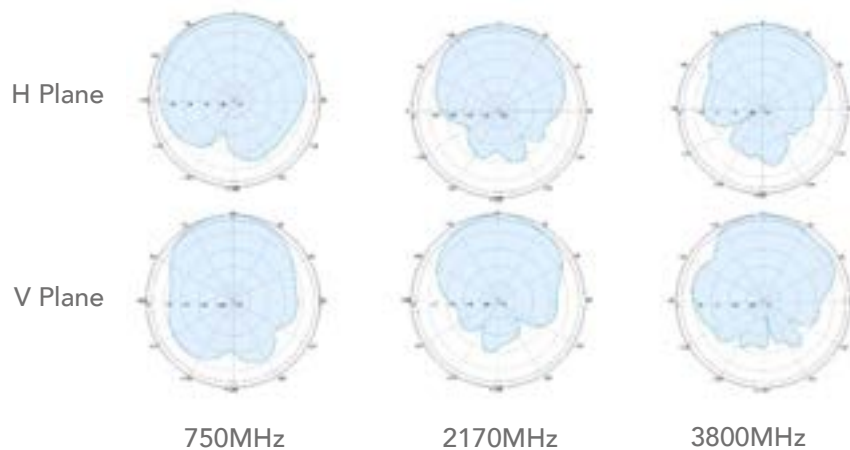

78712032

Indoor
Omnidirectional Antenna
H/H-Pol 2-port 3/6dBi
617-4000

Omni Indoor 617-4000 3/6dBi (Rectangular Card)

Type	78712032			
Frequency (MHz)	617-960	1425-2170	2300-2700	3300-4000
Gain (dBi)	3.0	4.0	6.0	5.5
VSWR	≤ 2.0	≤ 2.0	≤ 1.8	≤ 1.8
Polarization	H-H			
Isolation (dB)	20	23	23	23
PIM3 (dBc, @2x43dBm)	≤ -150			
Horizontal Beamwidth (°)	360			
Vertical Beamwidth (°)	113	78	65	102
Input Impedance (ohm)	50			
Max. Input Power (W)	50			
Lightning Protection	DC Grounded			
Connector	2 x 4.3-10 Female			
Dimension (mm)	250 X 150 X 12			
Weight (kgs)	Approx. 0.4			
Reflector Material	RF PCB			
Radome Material	ABS (UV Stabilized)			
Operating Temperature (°C)	-40 to +65			

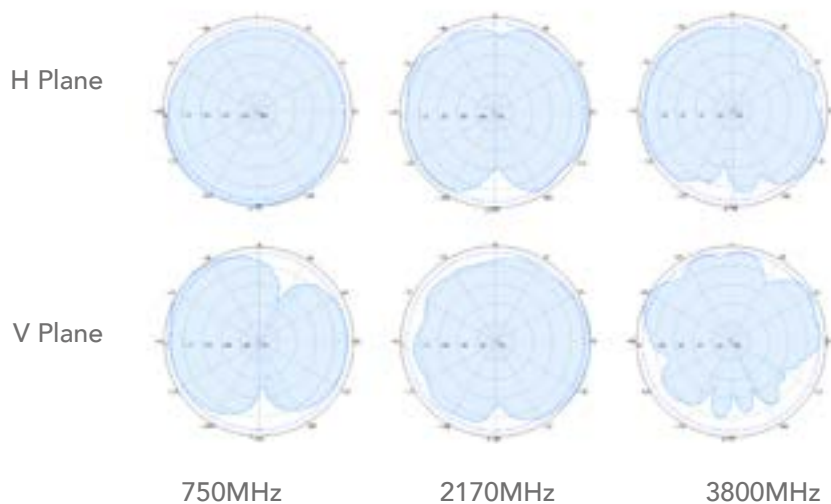

78712036

Indoor
Omni Antenna Ultra-Thin
H/H-Pol 2-port 4/6dBi
698-6000

Omni Indoor
698--6000 4/6dBi (Ultra-Thin)

Type	78712036			
Frequency (MHz)	698-960	1425-2170	3300-4000	4000-6000
Gain (dBi)	4.8	4.3	5.1	7.3
VSWR	≤ 1.8	≤ 1.7	≤ 1.7	≤ 1.7
Polarization	H-H			
Isolation (dB)	≥15	≥20	≥20	≥28
PIM3 (dBc, @2x43dBm)	≤ -153			
Horizontal Beamwidth (°)	360			
Vertical Beamwidth (°)	100-120	30-68	20-48	19-35
Input Impedance (ohm)	50			
Max. Input Power (W)	100			
Lightning Protection	Outer conductor of the connectors is DC grounded Inner conductor of the connectors is not DC grounded			
Connector	2 x 4.3-10 Female			
Dimension (mm)	Ø285 x 8			
Weight (kgs)	Approx. 0.5			
Radome Material	ABS (UV Stabilized)			
Operating Temperature (°C)	-40 to +65			

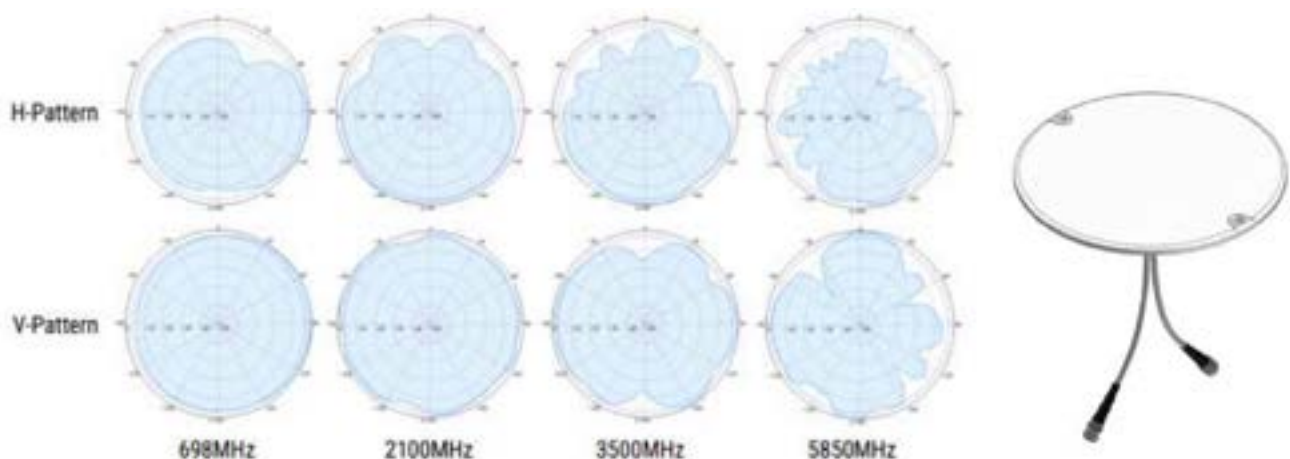

78712041

Omni Indoor 380-6000 2/3/6dBi (Dome)

Indoor
Omnidirectional Antenna (Dome)
V-Pol 1-port 2/3/6dBi
380-6000

Type	78712041				
Frequency (MHz)	380-520	600-960	1425-2700	2700-4000	4000-6000
Gain (dBi)	1.5	2.5	4.5	5.0	5.5
VSWR	≤ 2.5	≤ 2.0	≤ 2.0	≤ 2.0	≤ 2.0
Polarization	Vertical				
PIM3 (dBc, @2x43dBm)	≤ -153				
Horizontal Beamwidth (°)	360				
Vertical Beamwidth (°)	100	90	45	22	35
Input Impedance (ohm)	50				
Max. Input Power (W)	50				
Lightning Protection	DC Grounded				
Connector	1 x 4.3-10 Female				
Dimension (mm)	Ø285 x 135				
Weight (kgs)	Approx. 0.85				
Reflector Material	Aluminum				
Radome Material	ABS (UV Stabilized)				
Operating Temperature (°C)	-40 to +65				

(A)3WQMN41117194YR/3WQMN41117194YR
(A)4WQMN41117194YR/4WQMN41117194YR

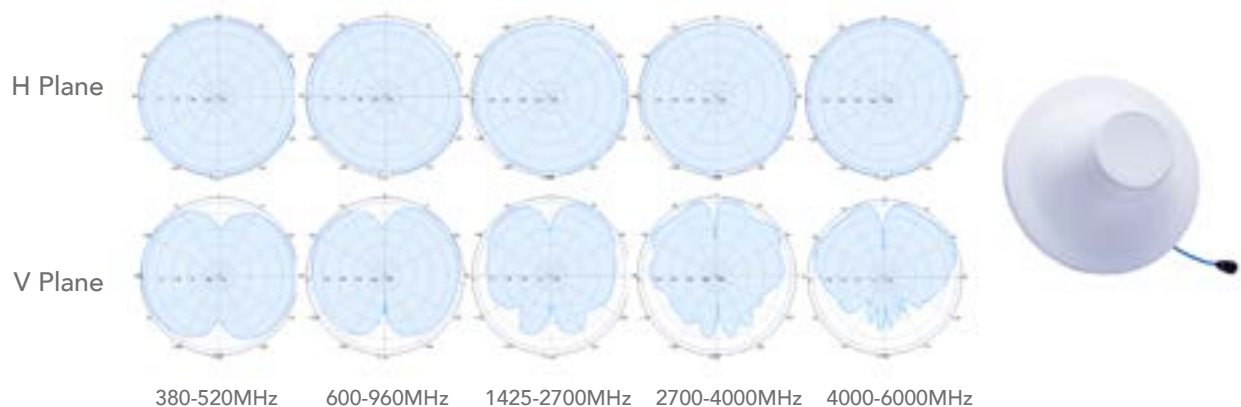

78712043 & 78712045

Indoor/Outdoor
Omni Antenna (Mini)
V-Pol 1-port 3/4dBi
698-4000

V-Pol Omni
698-4000 3/4dBi

Type	Cubic Column	78712043		
	Cylindrical Column	78712045		
Frequency Range (MHz)	698-960	1425-2700	3300-4000	
Gain (dBi)	3	4	4.5	
VSWR	≤ 1.8			
3rd Order PIM (dBc)	≤ -150 @ 2x43dBm			
Polarization	Vertical			
Horizontal Beamwidth (°)	360			
Vertical Beamwidth (°)	80	52	38	
Input Impedance (ohm)	50			
Max. Input Power (W)	100			
Lightning Protection	DC Grounded			
Connector Type	1 x 4.3-10 Female			
Dimension (mm)	66 x 66 x 190	Ø63 x 190		
Weight (kgs)	Cubic Column: 0.35	Cylindrical Column: 1.0		
Radome Material	UV-ABS			
Radiator Material	Aluminum			
Operating Temperature (°C)	-40 to +65			
Mounting	Mounting Clamp for Pole Ø38-Ø52 included			

78712043
Cubic Column



78712045
Cylindrical Column

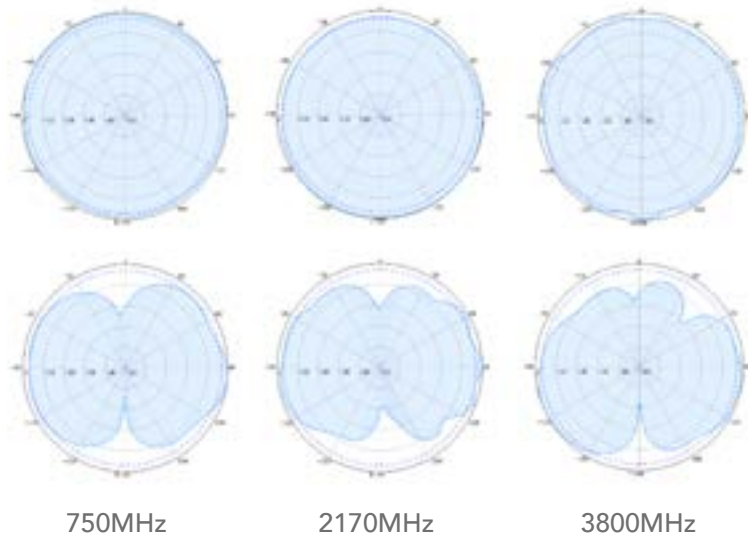

787x3160

Indoor
Omni Antenna
HH-Pol 4-port 4/5dBi
698-4000

Omni Indoor 698-4000 4/5dBi

Type	78713160		78733160
Frequency (MHz)	698-960	1425-2700	3300-4000
Gain (dBi)	3.5	4.0	4.5
VSWR	≤ 2.0	≤ 2.0	≤ 2.0
Polarization	H-H		
PIM3 (dBc, @2x43dBm)	≤ -153		
Isolation (dB)	≥ 15	≥ 20	≥ 22
Horizontal Beamwidth (°)	360		
Vertical Beamwidth (°)	90	46	38
Input Impedance (ohm)	50		
Max. Input Power (W)	50		
Lightning Protection	All metal parts (outer conductors) are DC grounded. Inner conductor is not DC grounded		
Connector	4 x 4.3-10 Female	4 x N Female	
Dimension (mm)	Ø320 x 50		
Weight (kgs)	Approx. 1.0		
Reflector material	Aluminium		
Radome Material	ABS (UV Stabilized)		
Operating Temperature (°C)	-40 to +65		



78715160**Omni Indoor
698-6000 4/8dBi (Ultra-Thin)**

Indoor
Omni Antenna (Ultra-Thin Plate)
H-Pol 4-port 4/8dBi
698-6000

Type	78715160			
Frequency (MHz)	698-960	1425-2700	3300-4000	4000-6000
Gain (dBi)	4.3	6.9	6.3	7.9
VSWR	≤ 1.8	≤ 1.7	≤ 1.7	≤ 1.7
Polarization	Horizontal			
PIM3 (dBc, @2x43dBm)	≤ -153			
Isolation (dB)	≥ 15	≥ 20	≥ 28	≥ 28
Horizontal Beamwidth (°)	360			
Vertical Beamwidth (°)	100-120	30-68	20-48	19-35
Input Impedance (ohm)	50			
Max. Input Power (W)	100			
Lightning Protection	DC Grounded			
Connector	4 x 4.3-10 Female			
Dimension (mm)	Ø355 x 14			
Weight (kgs)	Approx. 1.6			
Radome Material	ABS (UV Stabilized)			
Operating Temperature (°C)	-40 to +65			

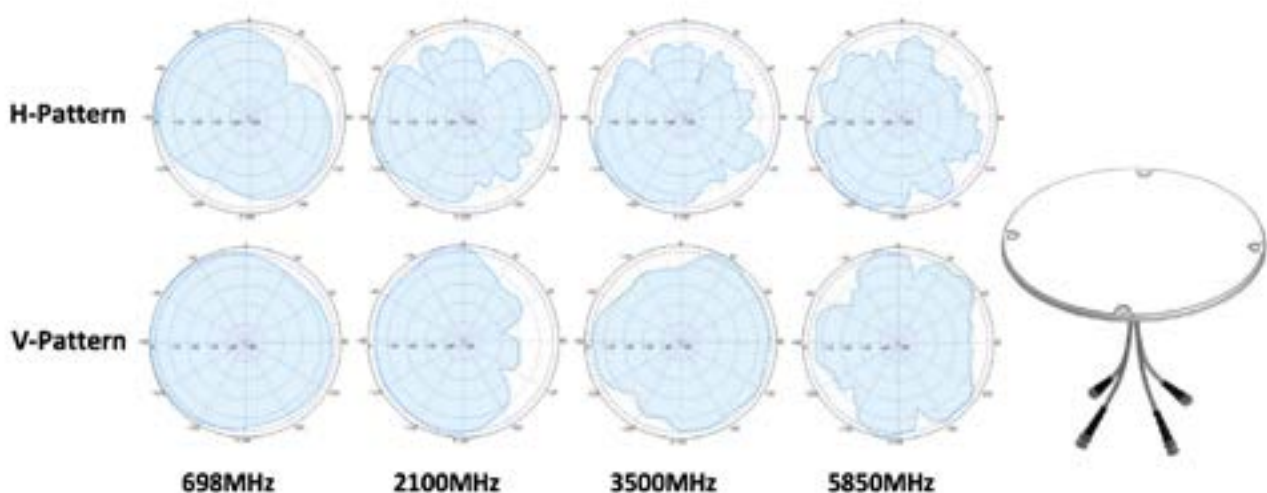

787x3130

Panel Indoor 698-4000 6/9dBi

Indoor
Panel Directional Antenna
VHPol 4-port 6/9dBi
698-4000

Type	78713130		78733130
Frequency (MHz)	698-960	1425-2700	3300-4000
Gain (dBi)	5.5	8.5	7.9
VSWR	≤ 2.0	≤ 2.0	≤ 2.0
Polarization	V-H		
PIM3 (dBc, @2x43dBm)	≤ -153		
Isolation (dB)	≥ 12	≥ 20	≥ 24
Front-to-Back Ratio (dB)	≥ 7	≥ 13	≥ 10
Horizontal Beamwidth (°)	130-85	95-58	65-33
Vertical Beamwidth (°)	108-78	83-45	90-25
Input Impedance (ohm)	50		
Max. Input Power (W)	50		
Lightning Protection	DC Grounded		
Connector	4 x 4.3-10 Female	4 x N Female	
Dimension (mm)	385 x 315 x 68		
Weight (kgs)	Approx. 1.5		
Reflector Material	Aluminum and PCB		
Radome Material	ABS (UV Stabilized)		
Operating Temperature (°C)	-40 to +65		
Mounting	Fixed wall mounting bracket included		
Optional accessory (*order separately)	Universal Mounting Bracket 70010008 Wall mount: ±25° horizontal swivel & +27°/-35° vertical tilt Pole mount: ±45° horizontal swivel; pole size Ø38-Ø52mm		



70120001 / 70120002

RF absorbing base for ESB omni ceiling antennas

Type	70120001	70120002
Mounting	30 x Ø260	30 x Ø360
Colour	ABS (UV Stabilized)	

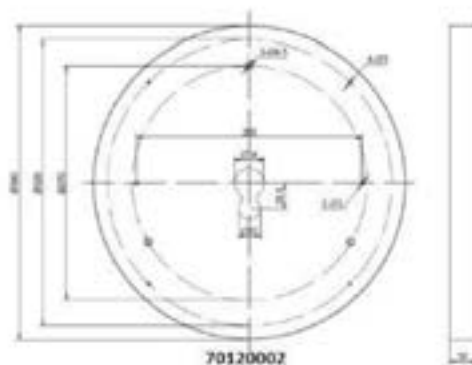
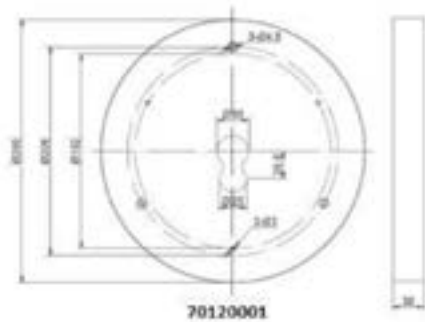
**Application of ESB absorbing base**

In general, omni ceiling-mounted antennas are installed on non-metallic surface and avoid being installed near any metallic object or surface to avoid RF interferences which could badly affect the antenna performance. When such installation becomes not possible, ESB RF Absorbing Base is used to minimize the RF interferences and improve the performance to acceptable level. ESB does not guarantee the operation of this device and highly recommends installing antennas on non-metallic surfaces

Low PIM splitters

ESB Low PIM splitters are designed to cover the most demanding networks starting from 380Mhz up to 6000Mhz. Round or squared tube are available as well as different connectors (4.3-10, 7/16 and N) for the most convenient scenario.

Part Number	Description	Page
78710131	2-way Splitter 340-3800 MHz 7/16	32
78710133	3-way Splitter 340-3800 MHz 7/16	32
78710134	4-way Splitter 340-3800 MHz 7/16	32
78761022v03	2-way Splitter 350-6000 MHz N	33
78761032v03	3-way Splitter 350-6000 MHz N	33
78761042v03	4-way Splitter 350-6000 MHz N	33
78761022v01	2-way Splitter 698-4000 MHz N	34
78761042	4-way Splitter 698-2700 MHz N	35
78710141	2-way Splitter 380-4000 MHz 4.3-10	36
78710143	3-way Splitter 380-4000 MHz 4.3-10	36
78710144	4-way Splitter 380-4000 MHz 4.3-10	36
78762023v01	2-way Splitter 555-6000 MHz 4.3-10	37
78762033v01	3-way Splitter 555-6000 MHz 4.3-10	37
78762043v01	4-way Splitter 555-6000 MHz 4.3-10	37
78762023	2-way Splitter 698-4000 MHz 4.3-10	38
78762033	3-way Splitter 698-4000 MHz 4.3-10	38
78762043	4-way Splitter 698-4000 MHz 4.3-10	38

7871013x

340-3800Mhz Outdoor Power Splitter
 2-/3-/4- Way Power Splitter
 Low PIM -160dBc
 500W DIN 7/16

Power Splitter 500W 340-3800 (Square Tube)

Type	78710131	78710133	78710134
Frequency (MHz)	340-3800		
Splitting Output	2-way	3-way	4-way
Distribution Loss (dB)	3.0	4.8	6.0
Insertion Loss (dB)	< 0.3	< 0.4	< 0.5
Return Loss (dB)	≥ 19		
PIM3 (dBc, @2x43dBm)	≤ -160		
Input Impedance (ohm)	50		
Max. Input Power (W)	500		
Connector	DIN 7/16 Female		
Weight (kgs)*	0.6	0.7	0.8
Dimension (mm)**	318 x 25 x 25	365 x 25 x 25	399 x 25 x 25
Ingress Protection Class	IP65 (for outdoor and indoor)		
Operating RH (%)	≤ 95		
Operating Temperature (°C)	-25 to +65		
Environmental data	Electromagnetic Compatibility 2014/30/EU RoHS compliance directive 2011/65/EU ETSI EN 300 019-1-4		
Mounting	Built-in Bracket for wall mount		
Colour	Light Grey		



787610X2v03Power Splitter
2-/3-/4-wayN 300W PIM -160dBc
350-6000MHz**Power Splitter
300W 350-6000 (Square Tube)**

Type	78761022v03	78761032v03	78761042v03
Frequency (MHz)	350-6000		
Splitting Output	2-way	3-way	4-way
VSWR	≤1.25	≤1.25	≤1.25
Split Loss (dB)	≤3.5	≤5.6	≤7.1
PIM3 (dBc, @2x43dBm)	≤ -160		
Input Impedance (ohm)	50		
Max. Input Power (W)	300		
Peak Power (W)	1200		
Connector	N Female		
Weight (kgs)	0.5	0.6	0.65
Dimension (mm)	318 x 25 x 25	365 x 25 x 25	399 x 25 x 25
Dimension (mm)**	420x80x40	420x80x40	460x80x60
Ingress Protection Class	IP65 (for outdoor and indoor)		
Operating RH (%)	≤ 95		
Operating Temperature (°C)	-25 to +65		
Mounting	Built-in Bracket for wall mount		
Colour	Light Grey		

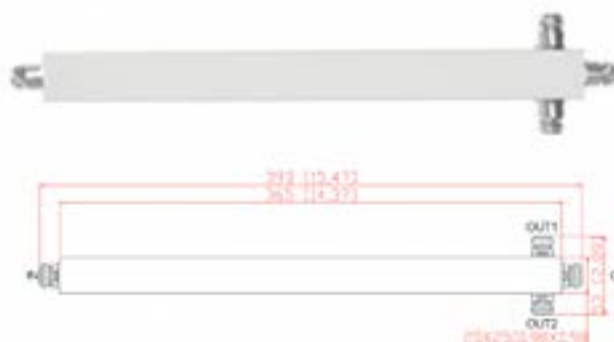

78761022v01

Power Splitter 300W 698-4000 (Round Tube)

Power Splitter 2 way
N 300W PIM -160dBc
698-4000MHz

Type	78761022v01
Frequency (MHz)	698-4000
Splitting Output	2-way
Distribution Loss (dB)	3.0
Insertion Loss (dB)	< 0.4
Return Loss (dB)	≥ 19
PIM3 (dBc, @2x43dBm)	≤ -160
Input Impedance (ohm)	50
Handling Power (W)	100
Peak Power (W)	1200
Connector	N Female (Screwed-in)
Weight (kgs)*	0.22
Dimension (mm)**	199.1 x 25 x 25
Ingress Protection Class	IP65 (for outdoor and indoor)
Operating RH (%)	≤ 95
Operating Temperature (°C)	-25 to +65
Mounting	Built-in Bracket for wall mount
Colour	Light Grey

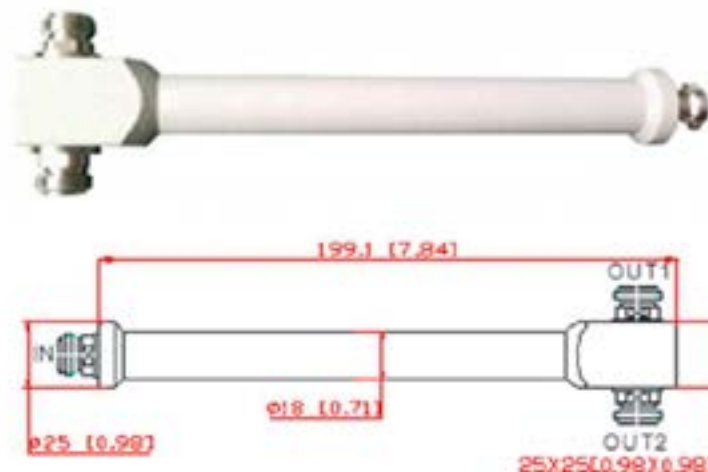

Power Splitter
300W 698-2700(Round Tube)

78761042

Power Splitter
 4-way N 300W
 PIM -155dB
 698-2700

Type	78761042
Frequency (MHz)	698-2700
Splitting Output	4-way
Distribution Loss (dB)	6.0
Insertion Loss (dB)	< 0.5
Return Loss (dB)	≥ 19
PIM3 (dBc, @2x43dBm)	≤ -155
Input Impedance (ohm)	50
Max. Input Power (W)	300
Max. Peak Power (W)	800
Connector	N Female (Screwed-in)
Weight (kgs)*	0.28
Dimension (mm)**	288.2 x 25 x 25
Ingress Protection Class	IP65 (for outdoor and indoor)
Operating RH (%)	≤ 95
Operating Temperature (°C)	-25 to +65
Mounting	Built-in Bracket for wall mount
Colour	Light Grey



* including mounting bracket and connectors
 ** excluding mounting bracket and connectors

7871014x

380-4000Mhz Outdoor Power Splitter
 2-/3-/4- Way Power Splitter
 Low PIM -160dBc
 500W 4.3-10 F

Power Splitter 500W 380-4000 (Square Tube)

Type	78710141	78710143	78710144
Frequency (MHz)	380-4000		
Splitting Output	2-way	3-way	4-way
Split Loss (dB)	≤3.5	≤5.6	≤6.8
PIM3 (dBc, @2x43dBm)	≤ -160		
Input Impedance (ohm)	50		
Handling Power (W)	500		
Peak Power (W)	1500		
Connector	4.3-10 Female		
Weight (kgs)	0.5	0.64	0.75
Dimension (mm)	318 x 25 x 25	365 x 25 x 25	399 x 25 x 25
Ingress Protection Class	IP65 (for outdoor and indoor)		
Operating RH (%)	≤ 95		
Operating Temperature (°C)	-25 to +65		
Environmental data	Electromagnetic Compatibility 2014/30/EU RoHS compliance directive 2011/65/EU ETSI EN 300 019-1-4		
Mounting	Built-in Bracket for wall mount		
Colour	Light Grey		

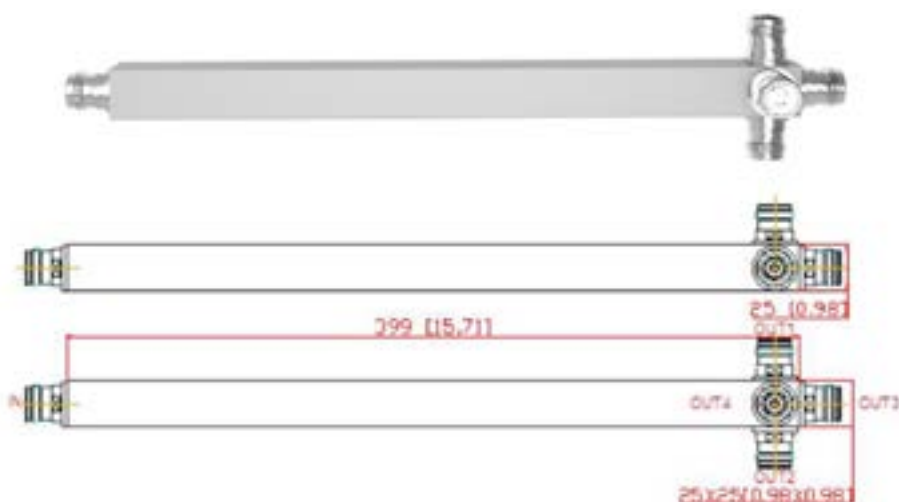

787620X3v01**Power Splitter
500W 555-6000 (Square Tube)**

Power Splitter
2- / 3- / 4-way 4.3-10F 500W
PIM -163dBc
555-6000Mhz

Type	78762023v01	78762033v01	78762043v01
Frequency (MHz)	555-6000		
Splitting Output	2-way	3-way	4-way
Distribution Loss (dB)	3.0	5.0	6.0
Insertion Loss (dB)	< 0.4	< 0.5	< 0.6
Return Loss (dB)	≥ 19		
VWSR	≤ 1.3		
PIM3 (dBc, @2x43dBm)	≤ -163		
Input Impedance (ohm)	50		
Max. Input Power (W)	500		
Peak Power (W)	1500		
Connector	4.3-10 Female (Screwed-in)		
Weight (kgs)	0.35	0.4	0.45
Dimension (mm)	218 x 25 x 25	269.2 x 25 x 25	269.20 x 25 x 25
Ingress Protection Class	IP65 (for outdoor and indoor)		
Operating RH (%)	≤ 95		
Operating Temperature (°C)	-40 to +80		
Mounting	Built-in Bracket for wall mount		
Colour	Light Grey		

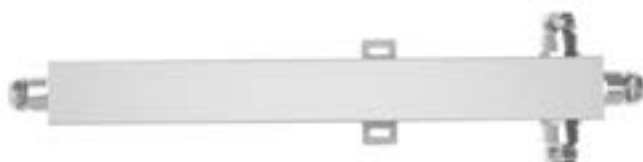

787620X3

Power Splitter
 2- / 3- / 4-way 4.3-10 500W
 PIM -160dBc
 698-4000

Power Splitter 500W 698-4000 (Round Tube)

Type	78762023	78762033	78762043
Frequency (MHz)	698-4000		
Splitting Output	2-way	3-way	4-way
Distribution Loss (dB)	3.0	4.8	6.0
Insertion Loss (dB)	< 0.4	< 0.5	< 0.6
Return Loss (dB)	≥ 19		
PIM3 (dBc, @2x43dBm)	≤ -160		
Input Impedance (ohm)	50		
Max. Input Power (W)	500		
Connector	4.3-10 Female (Screwed-in)		
Weight (kgs)	0.22	0.3	0.35
Dimension (mm)	199.1 x 25 x 25	233.6 x 25 x 25	236.1 x 25 x 25
Ingress Protection Class	IP65 (for outdoor and indoor)		
Operating RH (%)	≤ 95		
Operating Temperature (°C)	-25 to +65		
Mounting	Built-in Bracket for wall mount		
Colour	Light Grey		



78762043

* including mounting bracket and connectors
 ** excluding mounting bracket and connectors



Low PIM Directional Couplers

ESB Low PIM directional couplers allow to separate an incoming signal in two identical or two different shares with the output signals being very effectively de-coupled from each other. These directional couplers are designed to cover the most demanding networks starting from 380Mhz up to 6000Mhz. Different connectors are available (4.3-10 and N) for the most convenient scenario.

Part Number	Description	Page
78761106	6 dB Coupler 698-2700 MHz N	42
78761108	8 dB Coupler 698-2700 Mhz N	42
78761110	10 dB Coupler 698-2700 MHz N	42
78761115	15 dB Coupler 698-2700 MHz N	42
78761105v03	5 dB Coupler 350-6000 MHz N	43
78761106v03	6 dB Coupler 350-6000 MHz N	43
78761108v03	8 dB Coupler 350-6000 Mhz N	43
78761110v03	10 dB Coupler 350-6000 MHz N	43
78761115v03	15 dB Coupler 350-6000 MHz N	43
78761120v03	20 dB Coupler 350-6000 MHz N	43
78762105	5 dB Coupler 698-4000 4.3-10	44
78762106	6 dB Coupler 698-4000 4.3-10	44
78762108	8 dB Coupler 698-4000 4.3-10	44
78762110	10 dB Coupler 698-4000 4.3-10	44
78762115	15 dB Coupler 698-4000 4.3-10	44
78762120	20 dB Coupler 698-4000 4.3-10	44
78762130	30 dB Coupler 698-4000 4.3-10	44
78762105v01	5 dB Coupler 555-6000 4.3-10	45
78762106v01	6 dB Coupler 555-6000 4.3-10	45
78762108v01	8 dB Coupler 555-6000 4.3-10	45
78762110v01	10 dB Coupler 555-6000 4.3-10	45
78762115v01	15 dB Coupler 555-6000 4.3-10	45
78762120v01	20 dB Coupler 555-6000 4.3-10	45
78762130v01	30 dB Coupler 555-6000 4.3-10	45

787611XX

Directional Coupler 698-2700

Directional Coupler N
PIM -155dBc
698-2700

Type	78761106	78761108	78761110	78761115
Coupling Value (dB)	6	8	10	15
Coupling Bias (dB)	±0.8	±0.8	±1.0	±1.0
Insertion Loss (dB)	≤1.76	≤1.17	≤0.96	≤0.44
Isolation (dB)	≥24	≥26	≥28	≥33

Electrical Specifications	
Frequency Range (MHz)	698-2700
Impedance (Ω)	50
Return Loss (dB)	> 19
IM3 (dBc, @2x43dBm)	≤ -155
Max. Power Rating (W)	300
Peak Power (W)	800

Mechanical and Environmental Specifications	
Dimension (mm)**	126 x 45 x 25
Weight (kgs)*	0.53
Colour	Light Grey
Mounting	Wall Mount with Bracket
Operating Temp (°C)	-25 to +65
Ingress Protection Class	IP65
Packing Dimension (mm)	180 x 100 x 55
SKU (unit per box)	40 pcs per inner carton



* including mounting bracket and connectors
** excluding mounting bracket and connectors

787611XXv03

Directional Coupler NF
PIM -160dBc
350-6000MHz

Directional Coupler 350-6000Mhz

Type	78761105v03	78761106v03	78761108v03
Coupling Value (dB)	5	6	8
Coupling Bias (dB)	±2.0	±2.0	±2.0
Insertion Loss (dB)	≤3.0	≤1.8	≤1.5
Isolation (dB)350-4800	≥22	≥23	≥26
Isolation(dB)4800-6000	≥20	≥21	≥22
VSWR	≤1.3 (350-4800Mhz) ≤1.40 (4800-6000MHz)		

Type	78761110v03	78761115v03	78761120v03
Coupling Value (dB)	10	15	20
Coupling Bias (dB)	±2.0	±2.3	±2.3
Insertion Loss (dB)	≤1.1	≤0.8	≤0.22
Isolation (dB)350-4800	≥28	≥33	≥38
Isolation(dB)4800-6000	≥23	≥30	≥35
VSWR	≤1.3 (350-4800Mhz) ≤1.40 (4800-6000MHz)		

Electrical Specifications	
Frequency Range (MHz)	350-6000
Impedance (Ω)	50
IM3 (dBc, @2x43dBm)	≤ -160
Connector Type	N female
Max. Power Rating (W)	200
Peak Power (W)	1,200

Mechanical and Environmental Specifications	
Dimension (mm)**	156.90 x 44 x 31
Weight (kgs)*	0.6
Colour	Light Grey
Mounting	Wall Mount
Operating Temp (°C)	-35 to +85
Ingress Protection Class	IP65
Packing Dimension (mm)	180 x 100 x 55

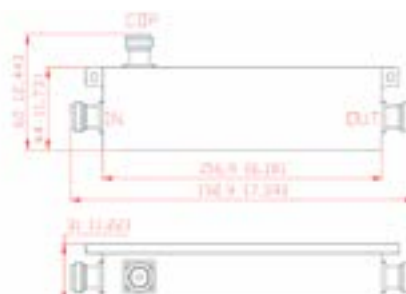

* including mounting bracket and connectors
** excluding mounting bracket and connectors

787621XX

Directional Coupler 4.3-10
PIM -160dBc
698-4000

Directional Coupler 698-4000

Type	78762105	78762106	78762108	78762110
Coupling Value (dB)	5	6	8	10
Coupling Bias (dB)	±1.0	±1.0	±1.0	±1.5
Insertion Loss (dB)	≤2.3	≤1.8	≤1.3	≤0.8
Isolation (dB)	≥23	≥24	≥26	≥28

Type	78762115	78762120	78762130
Coupling Value (dB)	15	20	30
Coupling Bias (dB)	±1.5	±1.5	±1.5
Insertion Loss (dB)	≤0.4	≤0.4	≤0.2
Isolation (dB)	≥38	≥38	≥45

Electrical Specifications	
Frequency Range (MHz)	698-4000
Impedance (Ω)	50
Return Loss (dB)	> 21 (Freq ≤ 2700MHz); > 19 (Freq 2700-4000MHz)
Directivity (dB)	> 20 (Freq ≤ 2700MHz); > 18 (Freq 2700-4000MHz)
IM3 (dBc, @2x43dBm)	≤ -160
Connector Type	4.3-10
Max. Power Rating (W)	500
Peak Power (W)	1,500

Mechanical and Environmental Specifications	
Dimension (mm)**	137 x 47.3 x 26
Weight (kgs)*	0.45
Colour	Light Grey
Mounting	Wall Mount
Operating Temp (°C)	-35 to +85
Ingress Protection Class	IP65
Packing Dimension (mm)	250 x 95 x 45
SKU (unit per box)	30 pcs per inner carton



* including mounting bracket and connectors
** excluding mounting bracket and connectors

787621XXv01

Directional Coupler 4.3-10
PIM -160dBc
555-6000

Air Dielectric directional Coupler 555-6000MHz

Type	78762105v01	78762106v01	78762108v01	78762110v01
Coupling Value (dB)	5	6	8	10
Coupling Bias (dB)	±1.4	±1.4	±1.1	±1.6
Insertion Loss (dB)	≤2.2	≤1.8	≤1.1	≤0.8
Isolation (dB)	≥21	≥23	≥25	≥28

Type	78762115v01	78762120v01	78762130v01
Coupling Value (dB)	15	20	30
Coupling Bias (dB)	±1.6	±1.6	±1.6
Insertion Loss (dB)	≤0.22	≤0.2	≤0.2
Isolation (dB)	≥31	≥36	≥45

Electrical Specifications	
Frequency Range (MHz)	555-6000
Impedance (Ω)	50
IM3 (dBc, @2x43dBm)	≤ -161
Connector Type	4.3-10
Max. Power Rating (W)	500
Peak Power (W)	1,500

Mechanical and Environmental Specifications	
Dimension (mm)**	127 x 40 x 31
Packind dimension (mm)	190 x 85 x 45
Weight (kgs)*	0.6
Colour	Light Grey
Mounting	Wall Mount
Operating Temp (°C)	-35 to +85
Ingress Protection Class	IP65
Packing Dimension (mm)	430 x 400 x 105

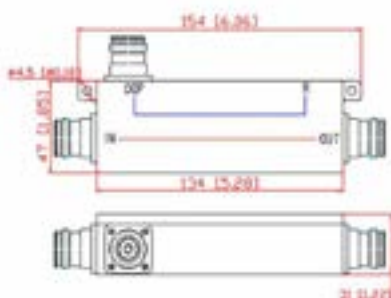

* including mounting bracket and connectors

** excluding mounting bracket and connectors

Stay tunned

Visit us on esbsistemas.com and discover the latest releases, news and updates of our products

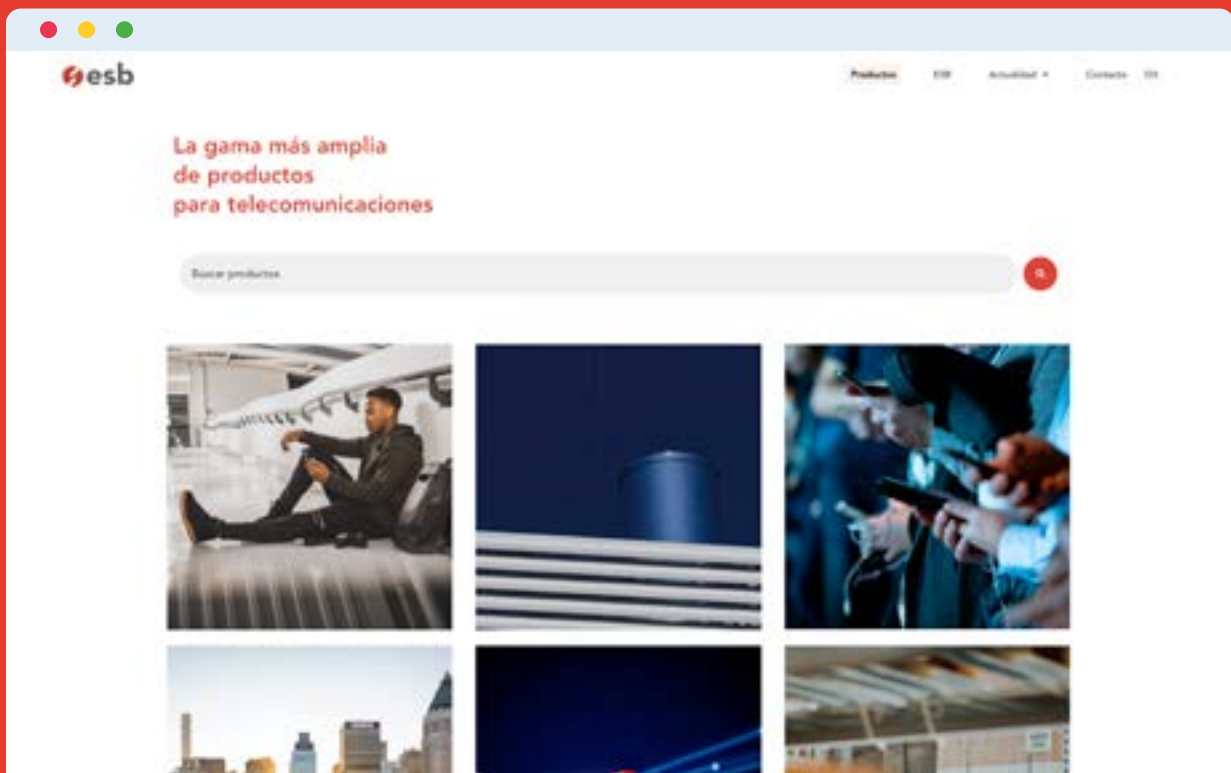



RF Tappers

Tappers are designed to split a signal into unequal parts respectively to tap off a signal portion from a main signal.

7872013X

698-4200Mhz RF Tapper
 7/10/15dB
 Low PIM -160dBc
 300W 4.3-10 F

RF Tapper
300W 698-4200 (Square Tube)

Type	78720136	78720137	78720138
Frequency (MHz)	698-4200		
Coupling (dB)	7±1.2	10±1.3	15±1.5
Insertion Loss	≤1.5	≤1.2	≤0.8
PIM3 (dBc, @2x43dBm)	≤ -160		
Input Impedance (ohm)	50		
Handling Power (W)	300		
Peak Power (W)	1500		
Connector	4.3-10 Female		
VSWR	≤1.35		
Weight (kgs)	0.3		
Dimension (mm) excluding connector	95 x 25 x 25		
Ingress Protection Class	IP65 (for outdoor and indoor)		
Operating RH (%)	≤ 95		
Operating Temperature (°C)	-55 to +65		
Environmental data	RoHS compliance directive 2011/65/EU		
Material data for housing	Aluminium + Powder coated		
Material data for connectors	Brass + CuSnZn3		
Mounting	Built-in Bracket for wall mount		
Colour	Light Grey		



Standard attenuators

Attenuators are used mainly where a power reduction is needed to reach a certain level in a transmission line. Different input power starting from 5W up to 100W can be found in our portfolio.

Part Number	Description	MHz	IM3 (dBc)	Input Power (W)	Connector Type	Page
78710305	3 dB Attenuator	DC-6000	-120	5	N F/M	52
78710605	6 dB Attenuator	DC-6000	-120	5	N F/M	52
78711005	10 dB Attenuator	DC-6000	-120	5	N F/M	52
78712005	20 dB Attenuator	DC-6000	-120	5	N F/M	52
78710315	3 dB Attenuator	DC-4000	-120	5	4.3-10 F/M	54
78710615	6 dB Attenuator	DC-4000	-120	5	4.3-10 F/M	54
78710310	3 dB Attenuator	DC-4000	-120	10	4.3-10 F/M	55
78710610	6 dB Attenuator	DC-4000	-120	10	4.3-10 F/M	55
78711010	10 dB Attenuator	DC-4000	-120	10	4.3-10 F/M	55
78711510	15 dB Attenuator	DC-4000	-120	10	4.3-10 F/M	55
78712010	20 dB Attenuator	DC-4000	-120	10	4.3-10 F/M	55
78713010	30 dB Attenuator	DC-4000	-120	10	4.3-10 F/M	55
78714010	40 dB Attenuator	DC-4000	-120	10	4.3-10 F/M	55
78710385	3 dB Attenuator	DC-4000	-120	15	4.3-10 F/M	56
78710685	6 dB Attenuator	DC-4000	-120	15	4.3-10 F/M	56
78711085	10 dB Attenuator	DC-4000	-120	15	4.3-10 F/M	56
78711585	15 dB Attenuator	DC-4000	-120	15	4.3-10 F/M	56
78712085	20 dB Attenuator	DC-4000	-120	15	4.3-10 F/M	56
78713085	30 dB Attenuator	DC-4000	-120	15	4.3-10 F/M	56
78714085	40 dB Attenuator	DC-4000	-120	15	4.3-10 F/M	56
78710325	3 dB Attenuator	DC-4000	-120	25	4.3-10 F/M	57
78710625	6 dB Attenuator	DC-4000	-120		4.3-10 F/M	57
78711025	10 dB Attenuator	DC-4000	-120	25	4.3-10 F/M	57
78711525	15 dB Attenuator	DC-4000	-120	25	4.3-10 F/M	57
78712025	20 dB Attenuator	DC-4000	-120	25	4.3-10 F/M	57
78713025	30 dB Attenuator	DC-4000	-120	25	4.3-10 F/M	57
78714025	40 dB Attenuator	DC-4000	-120	25	4.3-10 F/M	57
78710345	3 dB Attenuator	DC-4000	-105	50	4.3-10 F/M	57
78710645	6 dB Attenuator	DC-4000	-105	50	4.3-10 F/M	57
78711045	10 dB Attenuator	DC-4000	-105	50	4.3-10 F/M	57
78711545	15 dB Attenuator	DC-4000	-105	50	4.3-10 F/M	58
78712545	20 dB Attenuator	DC-4000	-105	50	4.3-10 F/M	58
78713045	30 dB Attenuator	DC-4000	-105	50	4.3-10 F/M	58
78714045	40 dB Attenuator	DC-4000	-105	50	4.3-10 F/M	58
78710355	3 dB Attenuator	DC-4000	-105	100	4.3-10 F/M	59
78710655	6 dB Attenuator	DC-4000	-105	100	4.3-10 F/M	59
78711055	10 dB Attenuator	DC-4000	-105	100	4.3-10 F/M	59
78761042	15 dB Attenuator	DC-4000	-105	100	4.3-10 F/M	59
78712055	20 dB Attenuator	DC-4000	-105	100	4.3-10 F/M	59
78713055	30 dB Attenuator	DC-4000	-105	100	4.3-10 F/M	59

7871xx05

Attenuator 5W N
DC-6000

Attenuator DC-6000 5W

Type	78710305	78710605	78711005	78712005
Attenuation (dB)	3	6	10	20
Attenuation Tolerance (dB)	±0.5	±0.5	±0.5	±0.8

Electrical Specifications	
Frequency (MHz)	DC - 6000
PIM3 (dBc, @2x33dBm)	≤ -120
Impedance (Ω)	50
Return Loss (dB)	≥ 21
Max Input Power (W)	5
Connector	N M/F

Mechanical and Environmental Specifications	
Dimension (mm)**	Ø205 x 65
Weight (kgs)*	0.08
Application	Indoor
Operating Temperature (°C)	-55 to +125
Operating RH (%)	≤ 95

Packing Information	
Packing Size (mm)	70 x 30 x 30
SKU (unit/inner carton)	100 pieces per inner carton/box



* including mounting bracket and connectors
** excluding mounting bracket and connectors



7871xx15

Attenuator 5W 4.3-10
DC-4000

Attenuator DC-4000 5W

Type	78710315	78710615
Attenuation (dB)	3	6
Attenuation Tolerance (dB)	±0.7	±0.7

Electrical Specifications	
Frequency (MHz)	DC - 4000
PIM3 (dBc, @2x33dBm)	≤ -120
Impedance (Ω)	50
Return Loss (dB)	≥ 21
Max Input Power (W)	5
Connector	4.3-10 F/M

Mechanical and Environmental Specifications	
Dimension (mm)**	Ø30 x 35
Weight (kgs)*	0.22
Ingress Protection	IP55
Operating Temperature (°C)	-55 to +125
Operating RH (%)	≤ 95

Packing Information	
Packing Size (mm)	70 x 30 x 30
SKU (unit/inner carton)	100 pieces per inner carton/box

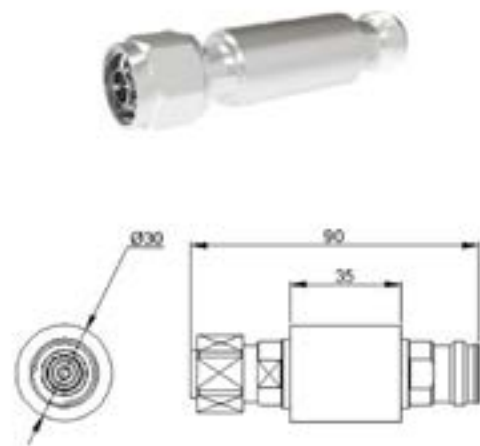

7871xx10

Attenuator 10W 4.3-10
DC-4000

Attenuator DC-4000 10W

Type	78710310	78710610	78711010	78711510
Attenuation (dB)	3	6	10	15
Attenuation Tolerance (dB)	±0.7	±0.7	±0.7	±0.7

Type	78712010	78713010	78714010
Attenuation (dB)	20	30	40
Attenuation Tolerance (dB)	±0.7	±0.8	±0.8

Electrical Specifications	
Frequency (MHz)	DC - 4000
PIM3 (dBc, @2x33dBm)	≤ -120
Impedance (Ω)	50
Return Loss (dB)	≥ 21
Max Input Power (W)	10
Connector	4.3-10 F/M

Mechanical and Environmental Specifications	
Dimension (mm)**	Ø55 x 69
Weight (kgs)*	4.3-10 F/M: 0.30
Ingress Protection	IP55
Operating Temperature (°C)	-55 to +125
Operating RH (%)	≤ 95

Packing Information	
Packing Size (mm)	160 x 70 x 70
SKU (unit/inner carton)	50 pieces per inner carton/box



* including mounting bracket and connectors
** excluding mounting bracket and connectors

7871xx85

Attenuator 15W 4.3-10
DC-4000

Attenuator DC-4000 15W

Type	78710385	78710685	78711085	78711585
Attenuation (dB)	3	6	10	15
Attenuation Tolerance (dB)	±0.7	±0.7	±0.7	±0.7

Type	78712085	78713085	78714085
Attenuation (dB)	20	30	40
Attenuation Tolerance (dB)	±0.7	±0.8	±0.8

Electrical Specifications	
Frequency (MHz)	DC - 4000
PIM3 (dBc, @2x33dBm)	≤ -120
Impedance (Ω)	50
Return Loss (dB)	≥ 21
Max Input Power (W)	15
Connector	4.3-10 F/M

Mechanical and Environmental Specifications	
Dimension (mm)**	Ø60 x 55
Weight (kgs)*	4.3-10 F/M: 0.30
Ingress Protection	IP55
Operating Temperature (°C)	-55 to +125
Operating RH (%)	≤ 95

Packing Information	
Packing Size (mm)	160 x 70 x 70
SKU (unit/inner carton)	50 pieces per inner carton/box



* including mounting bracket and connectors
** excluding mounting bracket and connectors

7871xx25

Attenuator 25W 4.3-10
DC-4000

Attenuator DC-4000 25W

Type	78710325	78710625	78711025	78711525
Attenuation (dB)	3	6	10	15
Attenuation Tolerance (dB)	±0.7	±0.7	±0.7	±0.7

Type	78712025	78713025	78714025
Attenuation (dB)	20	30	40
Attenuation Tolerance (dB)	±0.7	±0.8	±0.8

Electrical Specifications	
Frequency (MHz)	DC - 4000
PIM3 (dBc, @2x33dBm)	≤ -120
Impedance (Ω)	50
Return Loss (dB)	≥ 21
Max Input Power (W)	25
Connector	4.3-10 F/M

Mechanical and Environmental Specifications	
Dimension (mm)**	Ø60 x 55
Weight (kgs)*	4.3-10 F/M: 0.30
Ingress Protection	IP55
Operating Temperature (°C)	-55 to +125
Operating RH (%)	≤ 95

Packing Information	
Packing Size (mm)	160 x 70 x 70
SKU (unit/inner carton)	50 pieces per inner carton/box

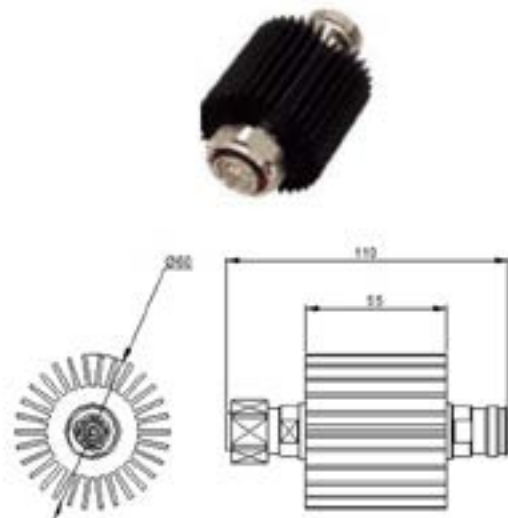

* including mounting bracket and connectors
** excluding mounting bracket and connectors

7871xx45

Attenuator 50W 4.3-10
DC-4000

Attenuator DC-4000 50W

Type	78710345	78710645	78711045	78711545
Attenuation (dB)	3	6	10	15
Attenuation Tolerance (dB)	±0.7	±0.7	±0.7	±0.7

Type	78712045	78713045	78714045
Attenuation (dB)	20	30	40
Attenuation Tolerance (dB)	±0.7	±0.8	±0.8

Electrical Specifications	
Frequency (MHz)	DC - 4000
PIM3 (dBc, @2x43dBm)	≤ -120
Impedance (Ω)	50
Return Loss (dB)	≥ 21
Max Input Power (W)	50
Connector	4.3-10 F/M

Mechanical and Environmental Specifications	
Dimension (mm)**	Ø60 x 85
Weight (kgs)*	4.3-10 F/M: 0.45
Ingress Protection	IP55
Operating Temperature (°C)	-55 to +125
Operating RH (%)	≤ 95

Packing Information	
Packing Size (mm)	160 x 70 x 70
SKU (unit/inner carton)	50 pieces per inner carton/box

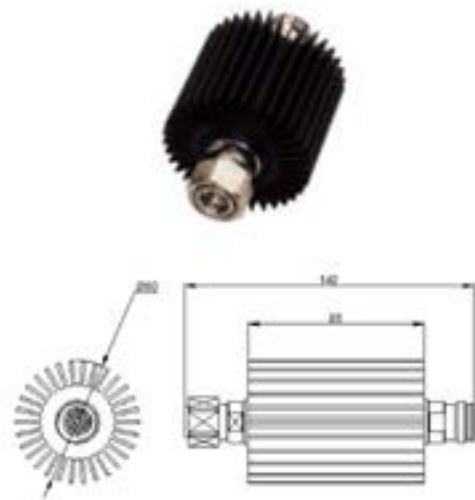

* including mounting bracket and connectors
** excluding mounting bracket and connectors

7871xx55

Attenuator 100W 4.3-10
DC-4000

Attenuator DC-4000 100W

Type	78710355	78710655	78711055	78711555
Attenuation (dB)	3	6	10	15
Attenuation Tolerance (dB)	±0.7	±0.7	±0.7	±0.7

Type	78712055	78713055
Attenuation (dB)	20	30
Attenuation Tolerance (dB)	±0.7	±0.8

Electrical Specifications	
Frequency (MHz)	DC - 4000
PIM3 (dBc, @2x43dBm)	≤ -105
Impedance (Ω)	50
Return Loss (dB)	≥ 21
Max Input Power (W)	100
Connector	4.3-10 F/M

Mechanical and Environmental Specifications	
Dimension (mm)**	Ø60 x 150
Weight (kgs)*	4.3-10 F/M: 0.95
Ingress Protection	IP55
Operating Temperature (°C)	-55 to +125
Operating RH (%)	≤ 95

Packing Information	
Packing Size (mm)	225 x 70 x 70
SKU (unit/inner carton)	50 pieces per inner carton/box



* including mounting bracket and connectors
** excluding mounting bracket and connectors

Low PIM attenuators

Low PIM Attenuators are used mainly where a power reduction is needed to reach a certain level in a transmission line keeping an excellent intermodulation level -160dBc. Different input power starting from 25W up to 200W with 4.3-10 connectors can be found in our portfolio.

Part Number	Description	MHz	IM3 (dBc)	Input Power (W)	Connector Type	Page
78720334	3 dB Attenuator	698 - 4000	-160	25	4.3-10 F/M	62
78720634	6 dB Attenuator	698 - 4000	-160	25	4.3-10 F/M	62
78721034	10 dB Attenuator	698 - 4000	-160	25	4.3-10 F/M	62
78721534	15 dB Attenuator	698 - 4000	-160	25	4.3-10 F/M	62
78722034	20 dB Attenuator	698 - 4000	-160	25	4.3-10 F/M	62
78723034	30 dB Attenuator	698 - 4000	-160	25	4.3-10 F/M	62
78710344	3 dB Attenuator	698 - 4000	-160	50	4.3-10 F/M	63
78710644	6 dB Attenuator	698 - 4000	-160	50	4.3-10 F/M	63
78711044	10 dB Attenuator	698 - 4000	-160	50	4.3-10 F/M	63
78711544	15 dB Attenuator	698 - 4000	-160	50	4.3-10 F/M	63
78712044	20 dB Attenuator	698 - 4000	-160	50	4.3-10 F/M	63
78713044	30 dB Attenuator	698 - 4000	-160	50	4.3-10 F/M	63
78710354	3 dB Attenuator	698 - 4000	-160	100	4.3-10 F/M	64
78710654	6 dB Attenuator	698 - 4000	-160	100	4.3-10 F/M	64
78711054	10 dB Attenuator	698 - 4000	-160	100	4.3-10 F/M	64
78711554	15 dB Attenuator	698 - 4000	-160	100	4.3-10 F/M	64
78712054	20 dB Attenuator	698 - 4000	-160	100	4.3-10 F/M	64
78713054	30 dB Attenuator	698 - 4000	-160	100	4.3-10 F/M	64
78710364	3 dB Attenuator	698 - 4000	-160	200	4.3-10 F/M	65
78710664	6 dB Attenuator	698 - 4000	-160	200	4.3-10 F/M	65
78711064	10 dB Attenuator	698 - 4000	-160	200	4.3-10 F/M	65
78711564	15 dB Attenuator	698 - 4000	-160		4.3-10 F/M	65
78712064	20 dB Attenuator	698 - 4000	-160	200	4.3-10 F/M	65
78713064	30 dB Attenuator	698 - 4000	-160	200	4.3-10 F/M	65

7872xx34

Attenuator 698-4000 25W

Low PIM Attenuator 25W 4.3-10
698-4000

Type	78720334	78720634	78721034	78721534	78722034	78723034
Attenuation (dB)	3	6	10	15	20	30
Attenuation Tolerance (dB)	±0.6	±1.0	±1.0	±1.0	±1.3	±1.3

Electrical Specifications	
Frequency (MHz)	698 - 4000
PIM3 (dBc, @2x43dBm)	≤ -160
Impedance (Ω)	50
Return Loss (dB)	≥ 19
Max Input Power (W)	25
Connector	4.3-10 F/M

Mechanical and Environmental Specifications	
Dimension (mm)**	202 x 80 x 38
Weight (kgs)*	1.6
Ingress Protection	IP65
Operating Temperature (°C)	-40 to +65
Operating RH (%)	≤ 95

Packing Information	
Packing Size (mm)	250 x 90 x 50
SKU (unit/inner carton)	8 pieces per inner carton/ box

Signal process
1. Signal is attenuated per above table in the forward direction (Input to Output)
2. Signal goes through without attenuation in the reverse direction (Output to Input) with max power 5W
3. Default orientation: Input= Male connector / Output= Female connector

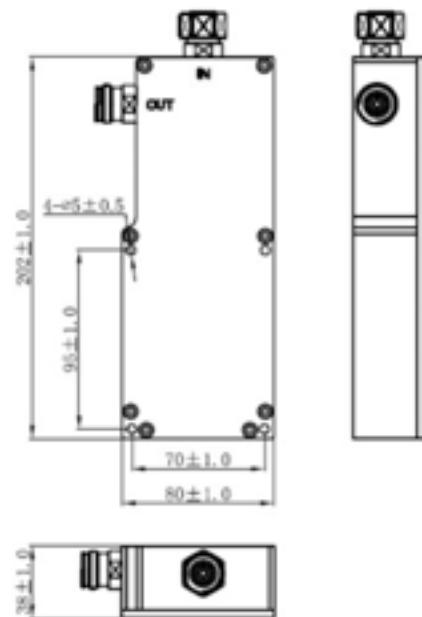

* including mounting bracket and connectors
** excluding mounting bracket and connectors

7871xx44

Low PIM Attenuator 50W 4.3-10
698-4000

Attenuator 698-4000 50W

Type	78710344	78710644	78711044	78711544	78712044	78713044
Attenuation (dB)	3	6	10	15	20	30
Attenuation Tolerance (dB)	±0.6	±1.0	±1.0	±1.0	±1.3	±1.3

Electrical Specifications	
Frequency (MHz)	698 - 4000
PIM3 (dBc, @2x43dBm)	≤ -160
Impedance (Ω)	50
Max Input Power (W)	50
Connector	4.3-10 F/M

Mechanical and Environmental Specifications	
Dimension (mm)**	220 x 128.7 x 70
Weight (kgs)*	3.0
Ingress Protection	IP65
Operating Temperature (°C)	-40 to +65
Operating RH (%)	≤ 95

Packing Information	
Packing Size (mm)	415 x 290 x 265
SKU (unit/inner carton)	4 pieces per inner carton/ box

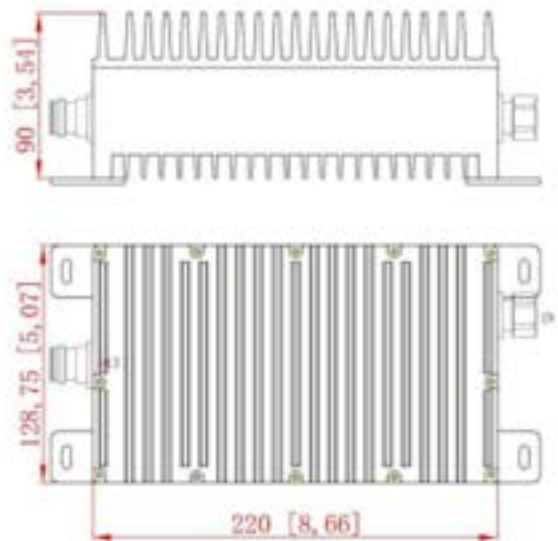

* including mounting bracket and connectors
** excluding mounting bracket and connectors

7871xx54

Low PIM Attenuator 100W 4.3-10
698-4000

Attenuator 698-4000 100W

Type	78710354	78710654	78711054	78711554
Attenuation (dB)	3	6	10	15
Attenuation Tolerance (dB)	±0.6	±1.0	±1.0	±1.0

Type	78712054	78713054
Attenuation (dB)	20	30
Attenuation Tolerance (dB)	±1.3	±1.3

Electrical Specifications	
Frequency (MHz)	698 - 4000
PIM3 (dBc, @2x43dBm)	≤ -160
Impedance (Ω)	50
Return Loss (dB)	≥ 19
Max Input Power (W)	100
Connector	4.3-10 F/M

Mechanical and Environmental Specifications	
Dimension (mm)**	176 x 176 x 97.5
Weight (kgs)*	4.3-10 F/M: 4.7
Ingress Protection	IP65
Operating Temperature (°C)	-40 to +65
Operating RH (%)	≤ 95

Packing Information	
Packing Size (mm)	415 x 290 x 265
SKU (unit/inner carton)	54 pieces per inner carton/ box

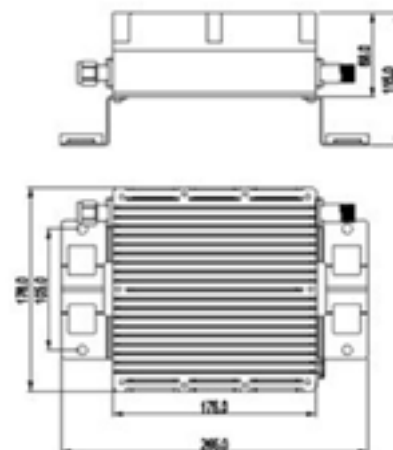

* including mounting bracket and connectors
** excluding mounting bracket and connectors

7871xx64

Attenuator 698-4000 200W

Low PIM Attenuator 200W 4.3-10
698-4000

Type	78710364	78710664	78711064	78711564	78712064	78713064
Attenuation (dB)	3	6	10	15	20	30
Attenuation Tolerance (dB)	±0.6	±1.0	±1.0	±1.0	±1.3	±1.3

Electrical Specifications	
Frequency (MHz)	698 - 4000
PIM3 (dBc, @2x43dBm)	≤ -160
Impedance (Ω)	50
Return Loss (dB)	≥ 19
Max Input Power (W)	200
Connector	4.3-10 F/M

Mechanical and Environmental Specifications	
Dimension (mm)**	250 x 176 x 97.5
Weight (kgs)*	4.3-10 F/M: 7.7
Ingress Protection	IP65
Operating Temperature (°C)	-40 to +65
Operating RH (%)	≤ 95

Packing Information	
Packing Size (mm)	415 x 365 x 285
SKU (unit/inner carton)	4 pieces per inner carton/box

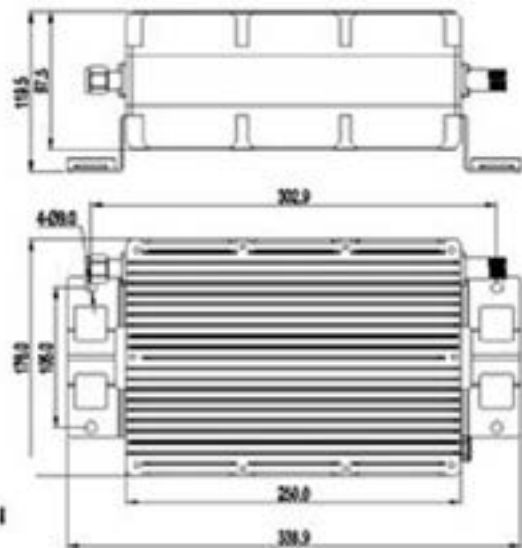

* including mounting bracket and connectors
** excluding mounting bracket and connectors

Loads & Low PIM loads

ESB Low PIM loads comprises a comprehensive portfolio for the most demanding mobile telecommunications networks in the market. They guarantee an excellent intermodulation level (-160dBc) as well as minimum VSWR values in order to avoid any reflect transmission. Low PIM loads can be found with different male or female 4.3-10 connectors.

Part Number	Description	MHz	IM3 (dBc)	Input Power (W)	Connector Type	Page
75110104	Termination Load	DC-6000	-160	10W	4.3-10-F	68
75120104	Termination Load	DC-6000	-160	10W	4.3-10-M	68
75110504	Termination Load	DC-4000	-160	50W	4.3-10-F	69
75120504	Termination Load	DC-4000	-160	50W	4.3-10-M	69
75111004	Termination Load	DC-4000	-160	100W	4.3-10-F	70
75121004	Termination Load	DC-4000	-160	100W	4.3-10-M	70
75112004	Termination Load	DC-4000	-160	200W	4.3-10-F	71
75122004	Termination Load	DC-4000	-160	200W	4.3-10-M	71
75110484	Termination Load	DC-6000	N/A	2W	4.3-10-M	72

751x0104

Termination Load 50ohm DC-6000 10W

Termination Load 50 ohm
Low PIM: -160dBc 10W
DC-6000 4.3-10: -Male / Female

Type	75110104 (4.3-10-Female)	75120104 (4.3-10-Male)
Power Rating (W)	10	
Frequency (MHz)	DC - 6000	
PIM3 (dBc)	-160	
Impedance (Ω)	50	
VSWR	≤ 1.20	
Dimension (mm)**	140 x φ63	
Weight (kgs)*	Female: 0.715	
	Male: 0.715	
Application	Indoor	
Packing dimensions	210 × 65 × 65	

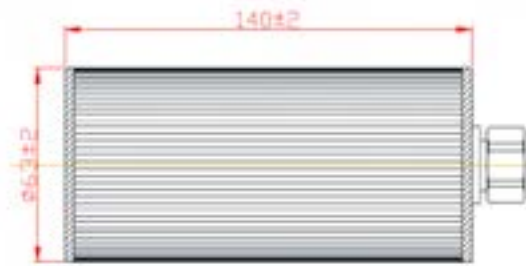

* including connector
** excluding connector

751x0504

Termination Load 50ohm DC-4000 50W

Termination Load 50 ohm
 Low PIM: -160dBc 50W
 DC-4000 4.3-10: -Male / Female

Type	75110504 (4.3-10-Female)	75120504 (4.3-10-Male)
Power Rating (W)	50	
Frequency (MHz)	DC - 4000	
PIM3 (dBc)	See Above Type Number Selection Table	
Impedance (Ω)	50	
VSWR	≤ 1.20	
Dimension (mm)**	180 x 150 x 62	
Weight (kgs)*	Female: 2.545 approx.	
	Male: 2.530 approx.	
Ingress Protection	IP65	

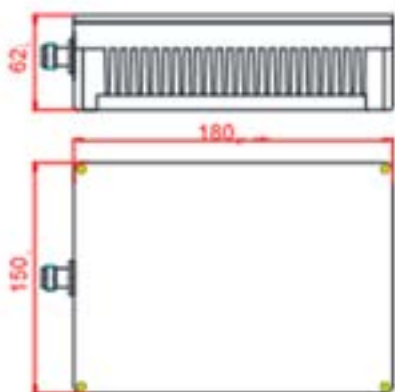

* including connector
 ** excluding connector

751X1004

Termination Load 50ohm DC-4000 100W

Termination Load 50 ohm
Low PIM: -160dBc 100W
DC-4000 4.3-10: -Male / Female

Type	75111004 (4.3-10-Female)	75121004 (4.3-10-Male)
Power Rating (W)	100	
Frequency (MHz)	DC - 4000	
PIM3 (dBc)	-160	
Impedance (Ω)	50	
VSWR	≤ 1.20	
Dimension (mm)**	180 x 150 x 62	
Weight (kgs)*	Female: 2.545 approx.	
	Male: 2.530 approx.	
Ingress Protection	IP65	
Operating temperature (°C)	-40 to +80	

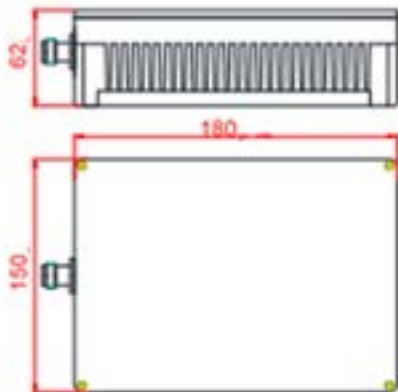

* including connector
** excluding connector

751X2004**Termination Load
50ohm DC-4000 200W**

Termination Load 50 ohm
 Low PIM: -160dBc 200W
 DC-4000 4.3-10: -Male / Female

Type	75112004 (4.3-10-Female)	75122004 (4.3-10-Male)
Power Rating (W)	200	
Frequency (MHz)	DC - 4000	
PIM3 (dBc)	-160	
Impedance (Ω)	50	
VSWR	≤ 1.20	
Dimension (mm)**	180 x 150 x 62	
Weight (kgs)*	Female: 2.595 approx.	
	Male: 2.580 approx.	
Ingress Protection	IP65	
Operating temperature ($^{\circ}\text{C}$)	-40 to +80	

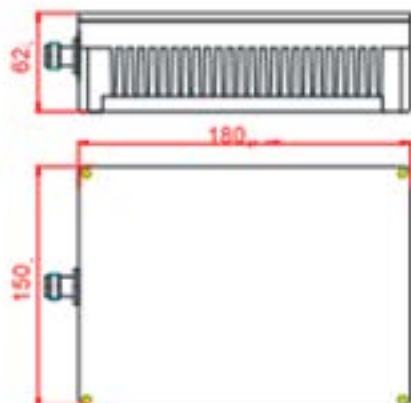

* including connector
 ** excluding connector

75110484

Termination Load 50ohm DC-6000 2W

2W Termination Load 50 ohm
DC-6000 4.3-10 Male

Type	75110484
Power Rating (W)	2
Frequency (MHz)	DC - 6000
Impedance (Ω)	50
VSWR	≤ 1.07 (0-1Ghz) ≤ 1.11 (1Ghz-2.5Ghz) ≤ 1.20 (2.5-6Ghz)
Dimension (mm)	37 x φ20
Weight (g)	Approx 60
Application	Indoor & outdoor
Operating temperature (°C)	-25 + 65°c







Antenna line products

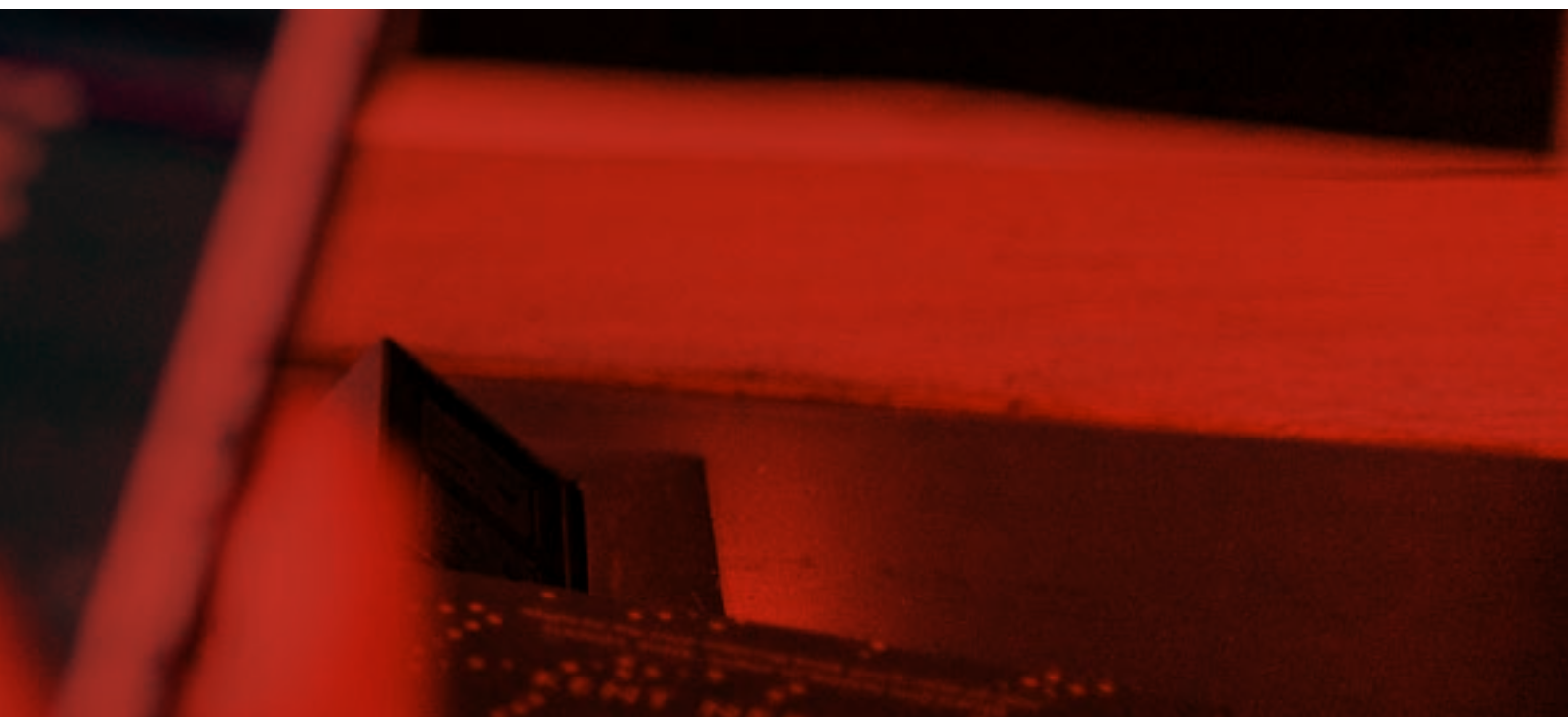

● **Antenna line products**

- Hybrid Combiners **_76**
- Special Antennas **_86**
- Smallcell Antennas **_100**
- Multi-band Combiners **_118**
- Trisector and Cannister antennas **_142**

Hybrid couplers & same band combiners

Low PIM ESB hybrid combiners are basically used to combine a signal into equal shares with the maximum port isolation needed in current mobile networks. 2x2, 3x3 and 4x4 versions are available covering different frequency range for each scenario.

Part Number	Description	MHz	IM3 (dBc)	Input Power (W)	Connector Type	Page
78211527	Hybrid combiner 2x2	698-4000	-160	500	4.3-10-F	78
78211527v01	Hybrid combiner 2x2	555-6000	-160	500	4.3-10-F	79
78211507	Hybrid combiner 2x1	698-4200	-160	500	4.3-10-F	80
78211380	Hybrid combiner 2x2	380-3800	-160	500	4.3-10-F	81
78211536v01	Hybrid combiner 4x4	698-4200	-160	500	4.3-10-F	82
78211533Hlv01	Hybrid combiner 3x3	698-4200	-160	500	4.3-10-F	83
78211359	Hybrid combiner 4x2	3300-5900	-161	500	4.3-10-F	84
78311235v01	Same band combiner	1800	-160	500	4.3-10-F	85

78211527

2:2 Hybrid Combiner 698-4000Mhz

Hybrid Combiner 2-in/2-out
PIM -160dBc
698-4000Mhz

Type	78211527
Frequency (MHz)	698-4000
Insertion Loss (dB)	3.1 ±0.6
VSWR	≤ 1.25
Isolation (dB)	≥ 25
PIM3 (dBc, @2x43dBm)	≤ -160
Input Impedance (ohm)	50
Max. Input Power (W)	500
Peak Power (W)	1500
Connector	4.3-10 Female
Weight (kgs)*	0.50
AISG/DC Bypass Path (2500mA Max)	IN1 ↔ OUT2 IN2 ↔ OUT1
Dimension (mm)**	158.9 x 42.60 x 29.5
Ingress Protection Class	IP65 (for outdoor and indoor)
Operating RH (%)	≤ 95
Operating Temperature (°C)	-40 to +65
Mounting	Wall Mount
Colour	Light Grey

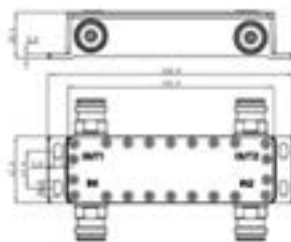
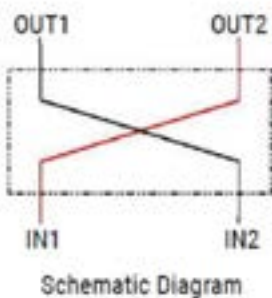

* including mounting bracket and connectors
** excluding mounting bracket and connectors

78211527v01

2:2 Hybrid Combiner 550-6000Mhz

Hybrid Combiner 2-in/2-out
PIM -160dBc
550-6000Mhz

Type	78211527v01
Frequency (MHz)	550-6000
Coupling (dB)	3
Insertion Loss (dB)	±1.4 (550-610Mhz) ±0.8 (610-6000Mhz)
VSWR	≤ 1.35
Isolation (dB)	≥ 23
PIM3 (dBc, @2x43dBm)	≤ -160
Input Impedance (ohm)	50
Max. Input Power (W)	200
Peak Power (W)	1000
Connector	4.3-10 Female
Weight (kgs)*	0.60
AISG/DC Bypass Path (2500mA Max)	IN1 ↔ OUT1 IN2 ↔ OUT2
Dimension (mm)**	131 x 40 x 38.4
Ingress Protection Class	IP65 (for outdoor and indoor)
Operating RH (%)	≤ 95
Operating Temperature (°C)	-40 to +65
Mounting	Wall Mount
Colour	Light Grey

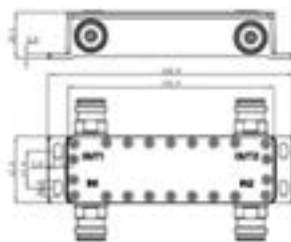
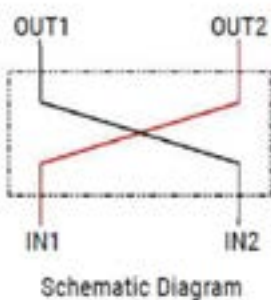

* including mounting bracket and connectors
** excluding mounting bracket and connectors

78211507

2:1 Hybrid Combiner 698-4200Mhz

Hybrid Combiner 2-in/1-out
PIM -160dBc
698-4200Mhz

Type	78211507
Frequency (MHz)	698-4200
Insertion Loss (dB)	≤3.6
VSWR	≤ 1.25
Isolation (dB)	≥ 23
PIM3 (dBc, @2x43dBm)	≤ -160
Input Impedance (ohm)	50
Max. Input Power (W)	500
Peak Power (W)	1,200
Connector	4.3-10 Female
Weight (kgs)*	0.60
Dimension (mm)**	180 x 150 x 62
Ingress Protection Class	IP65 (for outdoor and indoor)
Operating RH (%)	≤ 95
Operating Temperature (°C)	-40 to +65
Mounting	Wall Mount
Colour	Black

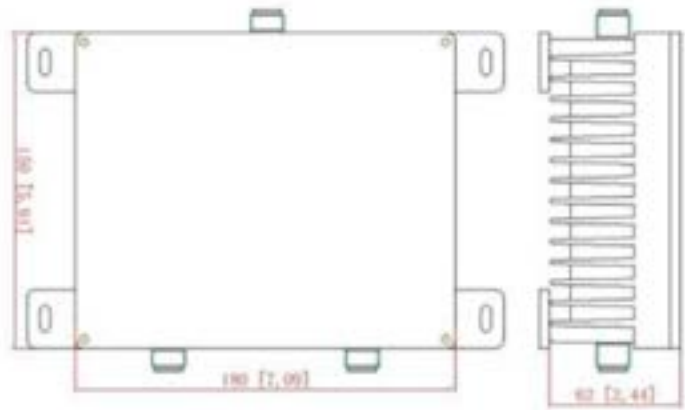

78211380

2:2 Hybrid Combiner 380-3800Mhz

Hybrid Combiner 2-in/2-out
PIM -160dBc
380-3800Mhz

Type	78211380
Frequency (MHz)	380-3800
Insertion Loss (dB)	3 ± 1.0
VSWR	≤ 1.25
Isolation (dB)	≥ 23
PIM3 (dBc, @2x43dBm)	≤ -160
Input Impedance (ohm)	50
Max. Input Power (W)	500
Peak Power (W)	1,500
Connector	4.3-10 Female
Weight (kgs)*	1.1 ± 0.55
AISG/DC Bypass Path (2500mA Max)	IN1 ↔ OUT1 IN2 ↔ OUT2
Dimension (mm)**	188.8 x 48 x 46
Ingress Protection Class	IP65 (for outdoor and indoor)
Operating RH (%)	≤ 95
Operating Temperature (°C)	-40 to +65
Mounting	Wall Mount
Colour	Light Grey

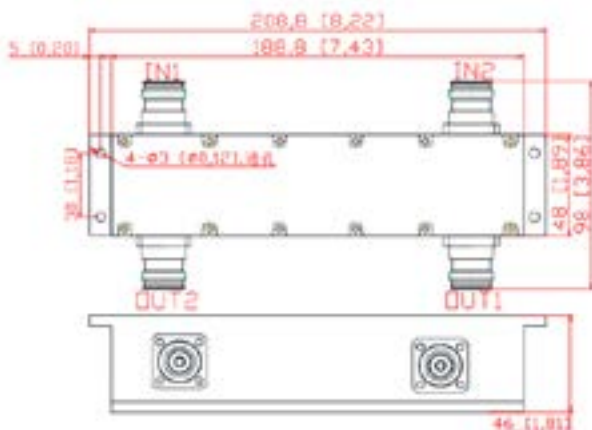

78211536v01

4:4 Hybrid Combiner 698-4200Mhz

Hybrid Combiner 4-in/4-out
PIM -160dBc
698-4200Mhz

Type	78211536v01	
Frequency (MHz)	698-4200	
Insertion Loss (dB)	698-2700: 6 ± 1.5	2700-4200: 6 ± 1.5
Return Loss (dB)	698-2700: ≥ 19	2700-4200: ≥ 18
VSWR	≤ 1.3	
Isolation (dB)	≥ 23	
PIM3 (dBc, @2x43dBm)	≤ -160	
Input Impedance (ohm)	50	
Max. Input Power (W)	500	
Peak Power (W)	1,500	
Connector	4.3-10 Female	
Weight (kgs)	2.2	
Dimension (mm)*	214 x 99.4 x 62	
Ingress Protection Class	IP65 (for outdoor and indoor)	
Operating RH (%)	≤ 95	
Operating Temperature (°C)	-40 to +65	
Mounting	Built-in Bracket for wall mount or pole mount	
Colour	Light Grey	

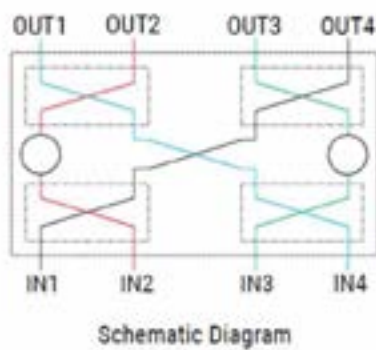
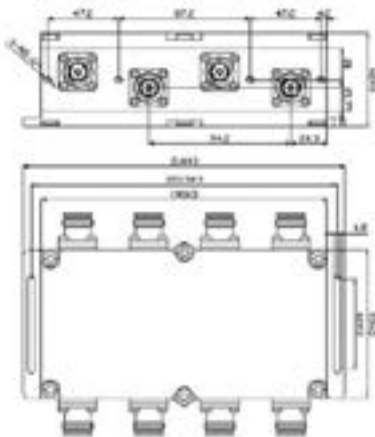

78211533Hlv01

Hybrid Combiner 3-in/3-out
 PIM -160dBc
 698-4200Mhz

3:3 Hybrid Combiner 698-4200Mhz

Type	78211533Hlv01
Frequency (MHz)	698-4200
Distribution Loss (dB)	≤ 5.5
Insertion Loss (dB)	±1.2
Isolation (dB)	≥ 25
PIM3 (dBc, @2x43dBm)	≤ -160
VSWR	≤ 1.30
Input Impedance (ohm)	50
Max. Input Power (W)	500
Peak Power (W)	1,500
AISG/DC Bypass Path (2500mA Max)	IN1 ↔ OUT3 IN2 ↔ OUT2 IN3 ↔ OUT1
Connector	4.3-10F
Dimension (mm)	235 x 107 x 41 (excluding mounting bracket and connectors)
Operating Temperature (°C)	-40 to +80
Operating Humidity (%)	≤ 95
Ingress Protection Class	IP65
Mounting	Wall Mount

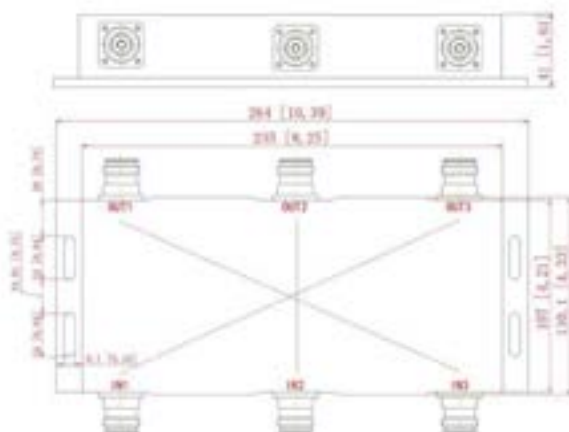

78211359

Dual Hybrid Combiner 3300-5925MHz, 4.3-10 F, -161dBc, IP65

Hybrid Combiner 4-in/2-out
PIM -161dBc
3300-5925Mhz

Type	78211359
Frequency (MHz)	3300-5925
Insertion Loss (dB)	3.2±0.5
Isolation (dB)	≥ 22
PIM3 (dBc, @2x43dBm)	≤ -161
VSWR	≤ 1.25
Input Impedance (ohm)	50
Input Power Peak power (W)	400
Peak Power (W)	1500
AISG carrier	2176KHz ± 100ppm
DC current/max AISG	2.5A
DC pass-through	Branch 2
Lightning surge current	10 kA
Lightning surge current waveform	8/20 waveform
Connector	4.3-10F
Dimension (mm, excluding bracket and connectors)	200x110x75
Operating Temperature (°C)	-40 to +80
Operational Humidity (%)	≤ 95
Ingress Protection	IP65
Mounting	Wall Mount or pole mount

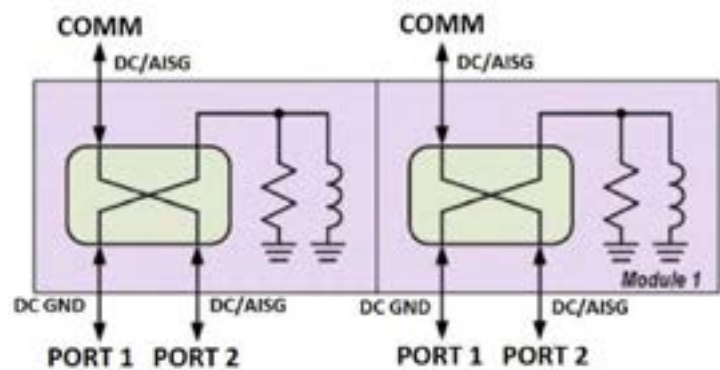

78311235v01

Outdoor Same-Band combiner
 1730-1750/1825-1845Mhz
 1765-1785/1860-1880MHz

Same-Band combiner

Type	78311235v01
Pass band frequency BTS 1 (LTE/GSM1800 / Operator 1) BTS 2 (LTE/GSM1800 / Operator 2)	Rx1/Rx2= 1730-1750Mhz, Tx1/Tx2= 1825-1845 Mhz Rx3/Rx4= 1765-1785MHz, Tx3/Tx4= 1860-1880 Mhz
Insertion Loss Port 1 ↔ Port 3 / Port 4 ↔ Port 6 Port 2 ↔ Port 3 / Port 5 ↔ Port 6	< 0.5 dB (1730-1750 MHz) / < 0.5 dB (1825-1845 MHz) < 0.5 dB (1765-1785 MHz) / < 0.5 dB (1860-1880 MHz)
Isolation Port1↔Port2 / Port4↔Port5	>30dB (1730-1750 / 1765-1785 / 1825-1845 / 1860-1880 MHz)
DC/AISG transparency (switchable) Port1↔Port3 / Port4↔Port6 Port2↔Port3 / Port5↔Port6	Stop By-pass (max. 2500 mA)
VSWR	< 1.25 (pass bands)
PIM3 (dBc, @2x43dBm)	≤ -160
Input Impedance (ohm)	50
Input Power Tx1/Tx2/Tx3/Tx4	< 100W / < 100W / < 100W / < 100W
Lightning Protection	3 kA, 10/350 μs pulse
Connector	4.3-10 female
Application	Indoor or outdoor (IP 66)
Dimension (mm)	287 x 171 x 218
Weight (kgs)	Approx. 5Kg
Mounting	Wall or mast pole
Operating Temperature (°C)	-40 to +65

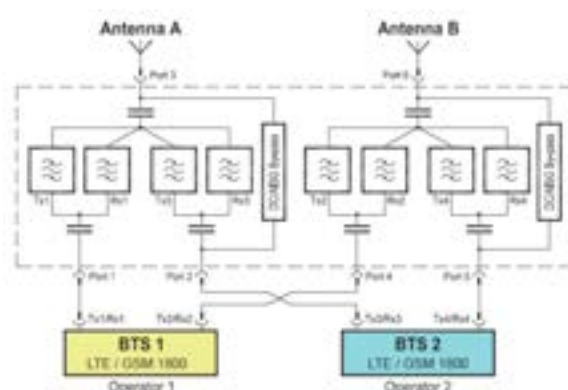
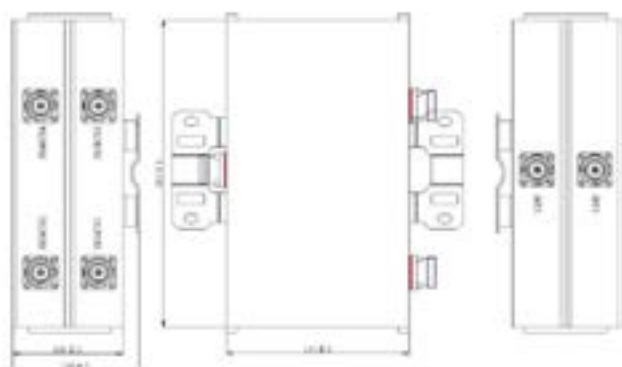

Special antennas

ESB special antennas are designed to deliver maximum performance in harsh environments in line with the most demanding new 5G networks. The product portfolio ranges from antennas for rural environments, through antennas for high gain tunnels and 2x2 MIMO technology to antennas designed for private networks.

Part Number	Type	Inputs	Connector	MHz	Gain (dB)	Page
80011747	Omni	2port	4.3-10-F	698-960	7.5dB	88
80011275	Omni	2port	4.3-10-F	1710-2700	10dB	89
80011274	Omni	2port	4.3-10-F	698-2700	8dB/10dB	90
80112014	Quasi-Omni	4port	4.3-10-F	698-2690	8dB/12dB	91
74212011	Log-per	1port	4.3-10F	698-4000	11dB	92
74252011	Log-per	1port	7/16F	698-4000	11dB	92
74212010	Log-per	1port	4.3-10F	698-4000	12/14dB	93
74252010	Log-per	1port	7/16F	698-4000	12/14dB	93
74212012	Log-per	2port	4.-3-10F	698-4000	10/11dB	94
74252012	Log-per	2port	7/16F	698-4000	10/11dB	94
74211014	Log-per	4port	4.3-10F	3300-3800	12dB	95
74231014	Log-per	4port	N-F	3300-3800	12dB	95
74212033	Log-per	2port	4.3-10F	2500-2700	14dB	96
74211025	Log-per	2port	4.3-10F	3300-3800	12dB	97
74211037	Log-per	2port	4.3-10F	3300-3800	15dB	98
78712071	Directional Pannel	2port	4.3-10F	2500-2700	19dB	99

80011747/2

Omni Antenna
 VV-Pol 2-port 7.5dBi
 698-960MHz

VV-Pol Omni 698-960Mhz 7.5dBi Outdoor

Type	80011747/2
Frequency Range (MHz)	698-960
Gain (dBi)	7.5
VSWR	≤ 1.7
3rd Order PIM (dBc)	≤ -150 @ 2x43dBm
Polarization	Vertical / Vertical
Horizontal Beamwidth (°)	360
Vertical Beamwidth (°)	15
Pre-set Electrical Tilt (°)	2
Input Impedance (ohm)	50
Max. Input Power (W)	250 per port
Lightning Protection	DC Grounded
Connector Type	2 x 4.3-10 Female
Dimension (mm)	Ø76 x 3,200
Weight (kgs)	10.5
Radome Material	Fiber Glass
Radiator Material	Copper
Operating Temperature (°C)	-40 to +65
Max. Wind Velocity (km/h)	210
Mounting	Mounting Clamp for Pole Ø60-Ø110 included

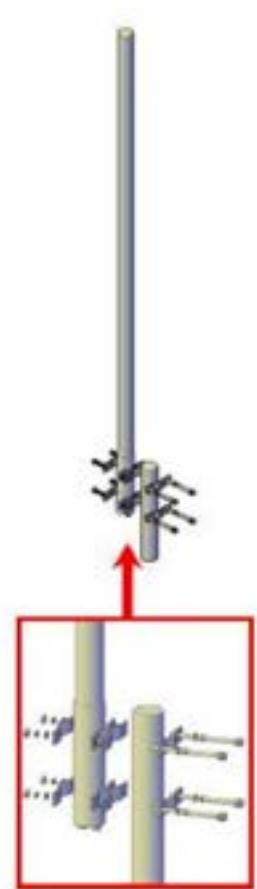

80011275

Omni Antenna
VV-Pol 2-port 10dBi
1710-2700Mhz

VV-Pol Omni 1710-2700Mhz 10dBi Outdoor

Type	80011275		
Frequency Range (MHz)	1695-2300	2300-2500	2500-2700
Gain (dBi)	9 ±0.5	10 ±0.5	9 ±0.5
VSWR	≤ 1.8	≤ 1.8	≤ 1.8
3rd Order PIM (dBc)	≤ -150 @ 2x43dBm		
Isolation	>20dB		
Polarization	Vertical / Vertical		
Horizontal Beamwidth (°)	360		
Vertical Beamwidth (°)	8	6	5
Ingress Protection Class	0		
Pre-set Electrical Tilt (°)	50		
Input Impedance (ohm)	-25 to +65		
Max. Input Power (W)	150 per port		
Lightning Protection	DC Grounded		
Connector Type	2 x 4.3-10 Female		
Dimension (mm)	Ø52 x 2,500		
Weight (kgs)	4		
Radome Material	Fiber Glass		
Radiator Material	Copper		
Operating Temperature (°C)	-40 to +65		
Max. Wind Velocity (km/h)	210		
Mounting	Mounting Clamp for Pole Ø60-Ø110 included		

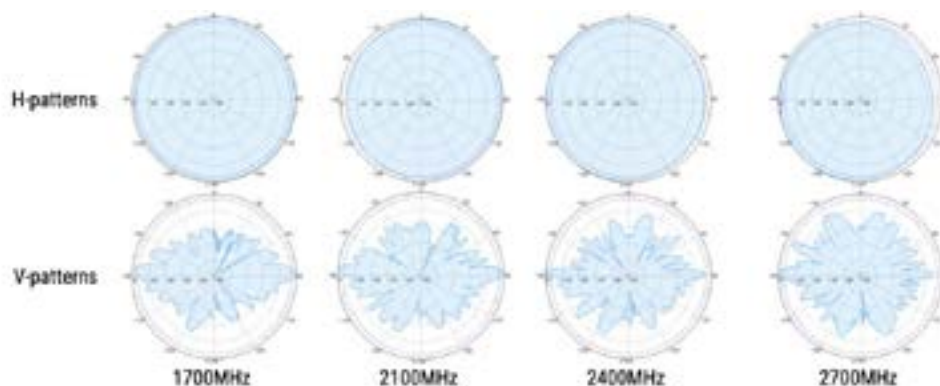

80011274

Dual Hybrid Combiner 3300-5925MHz, 4.3-10 F, -161dBc, IP65

Hybrid Combiner 4-in/2-out
PIM -161dBc
3300-5925Mhz

Type	80011274	
Band	R	Y
Frequency (MHz)	698-960	1710-2700
Gain (dBi)	8 ± 0.5	10 ± 0.5
VSWR	≤ 1.8	≤ 2.0
3rd Order PIM (dBc)	≤ -150 @ 2x43dBm	
Polarization	vertical / vertical	
Horizontal Beamwidth (°)	360	
Vertical Beamwidth (°)	14	9
Input Impedance (ohm)	50	
Max. Input Power (W)	100 per port	
Lightning Protection	DC Grounded	
Connector Type	1 x 4.3-10 female	1 x 4.3-10 female
Dimension (mm)	Ø76 x 3200	
Weight (kgs)	9.5	
Radome Material	Fiber Glass	
Operating Temperature (°C)	-40 to +65	
Max. Wind Velocity (km/h)	200	
Wind load (N), @150Km/h	209.49	
Mounting	Mounting Clamp for Pole Ø60-Ø110 included	

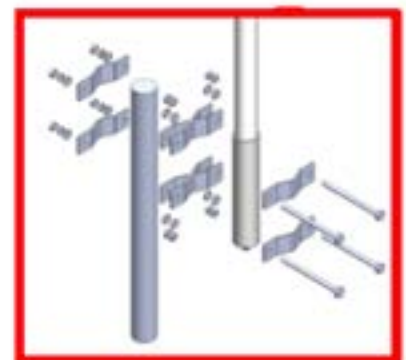
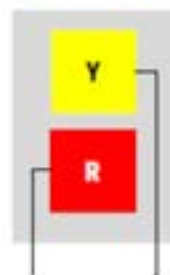
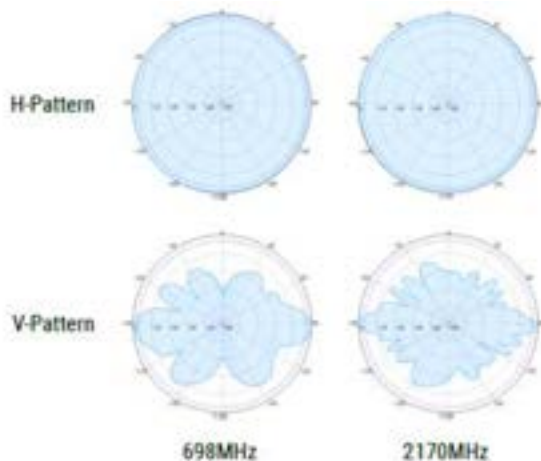

800112014

X-Pol Quasi-Omni
698-960 / 1710-2690 8/12dBi

Quasi-Omni Antenna
 XX-Pol 4-port 8/12dBi
 698-960 / 1710-2690

Type	80112014	
Frequency Range (MHz)	698-960	1710-2690
Gain (dBi)	8	12
VSWR	≤ 1.7	
3rd Order PIM (dBc)	≤ -150 @ 2x43dBm	
Polarization	±45°	
Isolation (dB)	≥ 18	≥ 18
Horizontal Beamwidth (°)	360	
Vertical Beamwidth (°)	12	7
Input Impedance (ohm)	50	
Max. Input Power (W)	250	
Lightning Protection	DC Grounded	
Connector Type	2 x 4.3-10 Female	2 x 4.3-10 Female
Dimension (mm)	Ø315 x 2,300	
Weight (kgs)	15	
Radome Material	Fiber Glass	
Reflector Material	Aluminum	
Operating Temperature (°C)	-40 to +65	
Max. Wind Velocity (km/h)	200	
Mounting	Floor Mount with Steel Stand (Supplied)	

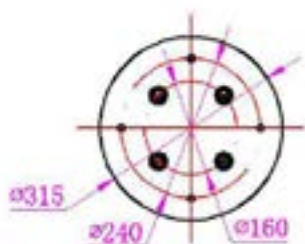
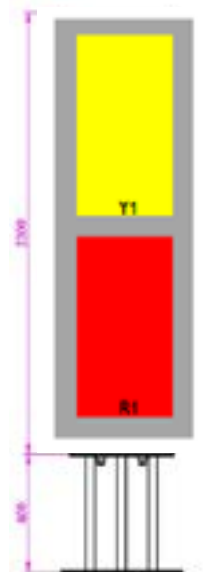

Bottom View - Antenna

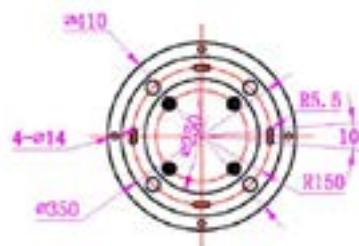

Bottom View - Stand

742x2011

Log Periodic Antenna 690-4000 11dBi

Log Periodic Antenna
V-Pol 1-port 11dBi
690-4000

Type	74212011			74252011		
Frequency Range (M Hz)	690-960	960-1695	1695-2200	2200-2490	2490-2690	3300-3800
Gain (dBi, typ.)	10.3	11.0	11.0	11.0	11.0	10.5
VSWR	≤ 1.5	≤ 1.5	≤ 1.5	≤ 1.5	≤ 1.5	≤ 1.5
Polarization	Vertical					
PIM3 (dBc), @2x43dBm	≤ -150					
Horizontal Beamwidth (°)	67	57	53	47	41	63
Vertical Beamwidth (°)	54	50	48	45	44	55
Front-to-Back Ratio (dB)	≥ 20	≥ 20	≥ 25	≥ 25	≥ 25	≥ 25
Input Impedance (Ω)	50					
Max. Input Power (W)	250	250	200	200	200	200
Lightning Protection	DC Grounded					
Connector Type	1 x 4.3-10 Female			1 x 7/16 Female		
Dimension (mm)	300 x 155 x 785					
Weight (kgs)	5.5					
Reflector Material	Aluminum					
Radome Material	Fiber Glass					
Rated Wind Velocity (km/h)	200					
Operating Temperature (°C)	-40 to +65					
Mounting	Pole Mount for Ø38 to Ø52 included					
Wind Load (N) (@150km/h Wind Speed)	Frontal: 25.5 Lateral: 143.1 Rearside: 41.8					
Complaint to Environmental Standards	Dry Heat	GB/T 2423.2		(IEC 60068-2-2)		
	Cold	GB/T 2423.1		(IEC 60068-2-1)		
	Damp Heat	GB/T 2423.3		(IEC 60068-2-78)		
	Change of Temperature	GB/T 2423.22		(IEC 60068-2-14)		
	Salt Mist	GB/T 2423.17		(IEC 60068-2-11)		
		GB/T 10125		(ISO 9227)		
	Ingress Protection	GB/T 4208		(IEC 60529)		
	Vibration	GB/T 2423.10		(IEC 60068-2-64)		
	Drop Test	GB/T 2423.8 & 4857.5		(ISO 2248)		

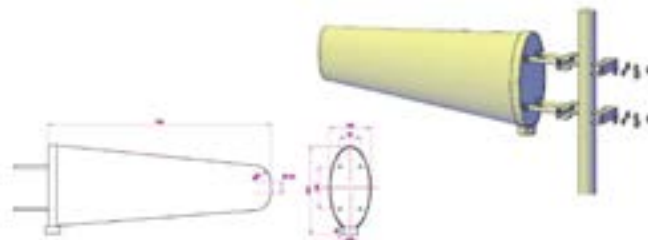

742x2010**Log Periodic Antenna
690-4000 12/14dBi**Log Periodic Antenna
V-Pol 1-port 12/14dBi
690-4000

Type	74212010		74252010		
Frequency Range (MHz)	690-806	806-960	1425-2170	2170-2700	3300-4000
Gain (dBi, typ.)	11.5	12.5	13.5	13.5	13.5
VSWR	≤ 1.5	≤ 1.5	≤ 1.5	≤ 1.5	≤ 1.5
Polarization	Vertical				
PIM3 (dBc), @2x43dBm	≤ -150				
Horizontal Beamwidth (°)	56	54	45	41	40
Vertical Beamwidth (°)	47	45	37	35	32
Front-to-Back Ratio (dB)	≥ 25	≥ 25	≥ 25	≥ 25	≥ 23
Input Impedance (Ω)	50				
Max. Input Power (W)	250				
Lightning Protection	DC Grounded				
Connector Type	1 x 4.3-10 Female		1 x 7/16 Female		
Dimension (mm)	250 x 200 x 1060				
Weight (kgs)	3.5				
Reflector Material	Copper				
Radome Material	Fiber Glass				
Rated Wind Velocity (km/h)	200				
Operating Temperature (°C)	-40 to +65				
Mounting	Pole Mount for Ø60 to Ø100 included				
Wind Load (N) (@150km/h Wind Speed)	Frontal: 33.3 Lateral: 124.5 Rearside: 54.6				
Complaint to Environmental Standards	Dry Heat	GB/T 2423.2		(IEC 60068-2-2)	
	Cold	GB/T 2423.1		(IEC 60068-2-1)	
	Damp Heat	GB/T 2423.3		(IEC 60068-2-78)	
	Change of Temperature	GB/T 2423.22		(IEC 60068-2-14)	
	Salt Mist	GB/T 2423.17		(IEC 60068-2-11)	
	Ingress Protection	GB/T 10125		(ISO 9227)	
	Vibration	GB/T 4208		(IEC 60529)	
	Drop Test	GB/T 2423.10		(IEC 60068-2-64)	
	GB/T 2423.8 & 4857.5		(ISO 2248)		

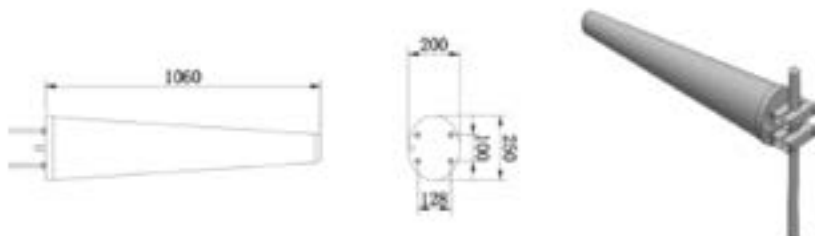

742x2012

Log Periodic Antenna 690-4000 11dBi

Log Periodic Antenna
H/V-Pol 2-port 11dBi
690-4000

Type	74212012			74252012	
	Frequency Range (MHz)	690-960	960-1695	1695-2170	2170-2690
Gain (dBi, typ.)	9.5	10.5	11.0	11.0	10.5
VSWR	≤ 1.8	≤ 1.6	≤ 1.6	≤ 1.6	≤ 1.6
Polarization	Vertical / Horizontal				
PIM3 (dBc), @2x43dBm	≤ -150				
Horizontal Beamwidth (°)	68	65	61	58	65
Vertical Beamwidth (°)	53	50	48	45	53
Isolation (dB)	≥ 20	≥ 20	≥ 28	≥ 28	≥ 28
Front-to-Back Ratio (dB)	≥ 20	≥ 20	≥ 25	≥ 25	≥ 25
Input Impedance (Ω)	50				
Max. Input Power (W)	200				
Lightning Protection	DC Grounded				
Connector Type	2 x 4.3-10 Female			2 x 7/16 Female	
Dimension (mm)	300 x 300 x 785				
Weight (kgs)	6.5				
Reflector Material	Aluminum				
Radome Material	Fiber Glass				
Rated Wind Velocity (km/h)	200				
Operating Temperature (°C)	-40 to +65				
Mounting	Pole Mount for Ø38 to Ø52 included				
Wind Load (N) (@150km/h Wind Speed)	Frontal: 25.5 Lateral: 143.1 Rearside: 41.8				
Complaint to Environmental Standards	Dry Heat	GB/T 2423.2		(IEC 60068-2-2)	
	Cold	GB/T 2423.1		(IEC 60068-2-1)	
	Damp Heat	GB/T 2423.3		(IEC 60068-2-78)	
	Change of Temp.	GB/T 2423.22		(IEC 60068-2-14)	
	Salt Mist	GB/T 2423.17		(IEC 60068-2-11)	
	Ingress Protection	GB/T 10125		(ISO 9227)	
	Vibration	GB/T 2423.10		(IEC 60068-2-64)	
	Drop Test	GB/T 2423.8 & 4857.5		(ISO 2248)	



742x1014

Log Periodic Antenna 3300-3800 12dBi

Log Periodic Antenna
XX-Pol4-port 12dBi
3300-3800MHz

Type	74211014	74231014	
Frequency Range (MHz)	3300-3800		
Gain (dBi, typ.)	12		
VSWR	≤ 1.5		
Polarization	±45°		
PIM3 (dBc), @2x43dBm	≤ -153		
Horizontal Beamwidth (°)	55		
Vertical Beamwidth (°)	48		
Front-to-Back Ratio (dB)	≥ 20		
Input Impedance (Ω)	50		
Max. Input Power (W)	200		
Lightning Protection	DC Grounded		
Connector Type	4 x 4.3-10 Female	4 x N Female	
Dimension (mm)	Ø203 x 200		
Weight (kgs)	1.8		
Radome Material	Fiber Glass (Grey)		
Operating Temperature (°C)	-40 to +65		
Mounting	Pole Mount		
Complaint to Environmental Standards	Dry Heat	GB/T 2423.2	(IEC 60068-2-2)
	Cold	GB/T 2423.1	(IEC 60068-2-1)
	Damp Heat	GB/T 2423.3	(IEC 60068-2-78)
	Change of Temperature	GB/T 2423.22	(IEC 60068-2-14)
	Salt Mist	GB/T 2423.17	(IEC 60068-2-11)
		GB/T 10125	(ISO 9227)
	Ingress Protection	GB/T 4208	(IEC 60529)
	Vibration	GB/T 2423.10	(IEC 60068-2-64)
	Drop Test	GB/T 2423.8 & 4857.5	(ISO 2248)



74212033

Log Periodic Antenna 2500-2700 14dBi

Log Periodic directional antenna X-Pol 2-port 2500-2700 14dBi

Type	74212033
Frequency Range (MHz)	2500-2700
Gain (dBi, typ.)	14
VSWR	≤ 1.5
Polarization	±45°
PIM3 (dBc), @2x43dBm	≤ -153
Front-to-Back Ratio (dB)	≥ 24
Isolation (dB)	≥ 25
Horizontal Beamwidth (°)	32
Vertical Beamwidth (°)	30
Input Impedance (Ω)	50
Max. Input Power (W)	200
Lightning Protection	DC Grounded
Connector Type	2 x 4.3-10 Female
Dimension (mm)	Ø180 x 500
Weight (kgs)	TBD
Max wind velocity (Km/h)	200
Wind Load (N) (@150km/h Wind Speed)	Frontal 22.92 Lateral 62.23 Rearside 40.11
Radome Material	Fiberglass, Gray (RAL7035)
Reflector Material	Aluminum
Operating Temperature (°C)	-40 to +65
Mounting	Clamps for Pole Size Ø38-Ø52mm included

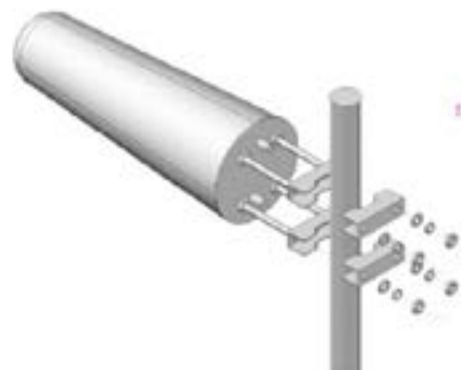
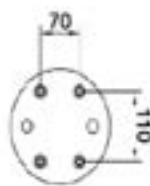
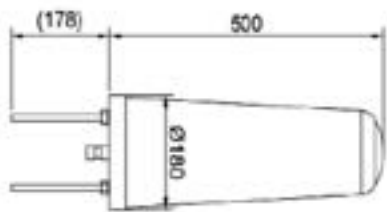

74211025

Log Periodic Antenna 3300-3800 12dBi

Log Periodic Antenna XPol
2-port 12dBi
3300-3800

Type	74211025		
Frequency Range (MHz)	3300-3800		
Gain (dBi, typ.)	12		
VSWR	≤ 1.5		
Polarization	±45°		
PIM3 (dBc), @2x43dBm	≤ -153		
Horizontal Beamwidth (°)	55		
Vertical Beamwidth (°)	48		
Front-to-Back Ratio (dB)	≥ 20		
Input Impedance (Ω)	50		
Max. Input Power (W)	200		
Lightning Protection	DC Grounded		
Connector Type	2 x 4.3-10 Female		
Dimension (mm)	Ø130 x 200		
Weight (kgs)	1.2		
Radome Material	Fiber Glass (Grey)		
Operating Temperature (°C)	-40 to +65		
Mounting	Pole Mount clamp (dacromet coated mild steel) included Pole size $\phi 38$ - $\phi 52$ mm		
Max wind velocity (Km/h)	210		
Wind Load (N) (@150km/h Wind Speed)	Frontal: 24.3 Lateral: 27.6 Rearside: 40.2		
Complaint to Environmental Standards	Dry Heat	GB/T 2423.2	(IEC 60068-2-2)
	Cold	GB/T 2423.1	(IEC 60068-2-1)
	Damp Heat	GB/T 2423.3	(IEC 60068-2-78)
	Change of Temperature	GB/T 2423.22	(IEC 60068-2-14)
	Salt Mist	GB/T 2423.17	(IEC 60068-2-11)
		GB/T 10125	(ISO 9227)
	Ingress Protection	GB/T 4208	(IEC 60529)
	Vibration	GB/T 2423.10	(IEC 60068-2-64)
	Drop Test	GB/T 2423.8 & 4857.5	(ISO 2248)

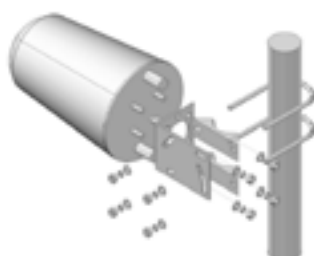

74211037

Log Periodic Antenna 3300-3800 15dBi

Log Periodic directional
antenna X-Pol 2-port
3300-3800 15dBi

Type	74211037		
Frequency Range (MHz)	3300-3800		
Gain (dBi, typ.)	15		
VSWR	≤ 1.5		
Polarization	±45°		
PIM3 (dBc), @2x43dBm	≤ -153		
Front-to-Back Ratio (dB)	≥ 20		
Isolation (dB)	≥ 20		
Horizontal Beamwidth (°)	33		
Vertical Beamwidth (°)	32		
Input Impedance (Ω)	50		
Max. Input Power (W)	200		
Lightning Protection	DC Grounded		
Connector Type	2 x 4.3-10 Female		
Dimension (mm)	Ø180 x 330		
Weight (kgs)	TBD		
Max wind velocity (Km/h)	200		
Wind Load (N) (@150km/h Wind Speed)	TBD		
Radome Material	Fiberglass, Gray (RAL7035)		
Reflector Material	Aluminum		
Operating Temperature (°C)	-40 to +65		
Mounting	Pole Mount		
Complaint to Environmental Standards	Dry Heat	GB/T 2423.2	(IEC 60068-2-2)
	Cold	GB/T 2423.1	(IEC 60068-2-1)
	Damp Heat	GB/T 2423.3	(IEC 60068-2-78)
	Change of Temperature	GB/T 2423.22	(IEC 60068-2-14)
	Salt Mist	GB/T 2423.17	(IEC 60068-2-11)
		GB/T 10125	(ISO 9227)
	Ingress Protection	GB/T 4208	(IEC 60529)
	Vibration	GB/T 2423.10	(IEC 60068-2-64)
	Drop Test	GB/T 2423.8 & 4857.5	(ISO 2248)

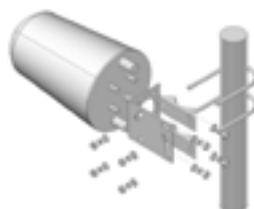

78712071 & 78712071/2

Directional Antenna 2500-2700 19dBi

Directional antenna
X-Pol 2-port 2500-2700
19dBi 35° with fixed
electrical D/T

Type	78712071	78712071/2
Frequency Range (MHz)	2500-2700	
Gain (dBi, typ.)	19	
VSWR	≤ 1.5	
Polarization	±45°	
PIM3 (dBc), @2x43dBm	≤ -153	
Front-to-Back Ratio (dB)	≥ 25	
Isolation (dB)	≥ 24	
Electrical Tilt (°)	0	2
Horizontal Beamwidth (°)	34	
Vertical Beamwidth (°)	7	
Input Impedance (Ω)	50	
Max. Input Power (W)	200	
Lightning Protection	DC Grounded	
Connector Type	2 x 4.3-10 Female	
Dimension (mm)	900 x 285 x 90	
Weight (kgs)	TBD	
Max wind velocity (Km/h)	210	
Wind Load (N) (@150km/h Wind Speed)	TBD	
Radome Material	UV-PVC	
Reflector Material	Aluminum	
Operating Temperature (°C)	-40 to +65	
Mounting	Adjustable D/T Clamp for Pole Size Ø50-Ø80 included	

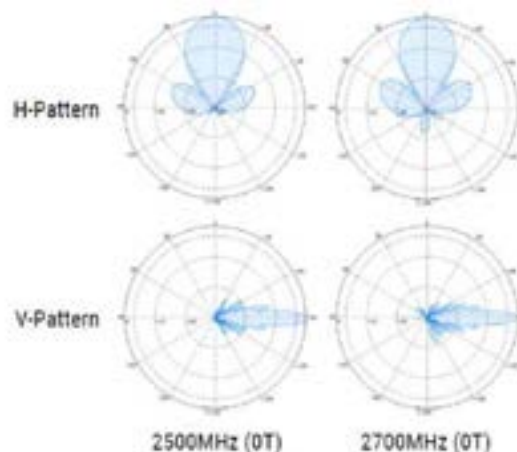

Smallcell antennas

The new 5G networks require a high consumption of small cells to provide more data capacity in densely populated areas. ESB offers different designs for each useful scenario focused on low weight, compact size and high performance.

Part Number	Description	Connector	MHz	Gain (dB)	Page
72432008	Log Periodic 698-960/1710-4000	N-F	1	8/9dBi	102
72412008	Log Periodic 698-960/1710-4000	4.3-10-F	1	8/9dBi	102
80011313v01	V-Pol Directional 698-2700	N-F	1	6/8dBi	103
80012323	V-Pol Directional 380-6000	4.3-10-F	1	3/8dBi	104
80013154	XX-Pol Directional 1695-4200	4.3-10-F	4	8/9dBi	105
80013130	V/H-Pol Directional 698-4200	4.3-10-F	4	6/9dBi	106
80112751	X-Pol Directional 1710-2690/3300-4000	4.3-10-F	2	8dBi	107
80112752	X-Pol Directional 1710-2690/3300-4000	4.3-10-F	2	11dBi	108
80112753	X-Pol Directional 698-3800	4.3-10-F	2	8/12dBi	109
80112754	XX-Pol Directional 698-4000	4.3-10-F	4	8/9dBi	110
80012065	X-Pol Directional 698-3800	4.3-10-F	2	13/13dBi	111
80020449v01	Bi-directional 698-3800	4.3-10-F	1	5dB/6dB	112
80011847	Omni 698-4000	4.3-10-F	1	3dB	113
80020452	Bi-directional 1710-4000	4.3-10-F	2	5dB/6dB	114
73410007	73410007 L-Bracket for antenna 80011847	N/A	N/A	N/A	115
70010015v01	Universal outdoor mounting bracket	N/A	N/A	N/A	116

724x2008

Log Periodic
698-960/1710-4000 8/9dBi

Log Periodic Antenna
V-Pol 1-port 8/9dBi
698-960 / 1710-4000

Type	72412008 (4.3-10 Female)	72432008 (N Female)
Frequency (MHz)	698-960	1710-2700
Gain (dBi)	8	9
VSWR	≤ 2.0	≤ 1.5
Polarization	Vertical	
PIM3 (dBc, @2x43dBm)	≤ -150	
Front-to-Back Ratio (dB)	≥ 15	
Horizontal Beamwidth (°)	95	78
Vertical Beamwidth (°)	68	56
Input Impedance (ohm)	50	
Max. Input Power (W)	50	
Lightning Protection	DC Grounded	
Connector	1 x 4.3-10 Female	1 x N Female
Dimension (mm)	249 x 210 x 65	
Weight (kgs)	Approx. 0.87	
Reflector Material	Aluminum	
Radome Material	ABS (UV Stabilized)	
Operating Temperature (°C)	-40 to +65	
Mounting	Pole-mount Clamp for Pole Size Ø38 to Ø52 Included	



80011313v01

Outdoor Directional
Panel Antenna
V-Pol 1-port 7/9dBi
698-960 / 1710-2700

Panel outdoor
698-960/1690-2700 7/9dBi

Type	80011313v01	
Frequency (MHz)	698-960	1690-2700
Gain (dBi)	6.5	9.0
VSWR	≤ 1.8	≤ 1.5
Polarization	Vertical	
PIM3 (dBc, @2x43dBm)	≤ -150	
Horizontal Beamwidth (°)	90	65
Vertical Beamwidth (°)	73	55
Input Impedance (ohm)	50	
Max. Input Power (W)	50	
Lightning Protection	DC Grounded	
Connector Type	N Female	
Dimension (mm)	168 x 158 x 50	
Weight (kgs)	Approx. 0.40	
Mounting	Standard fixed wall mount included *Optional Universal Bracket 70010015-V01 for wall or pole mount with universal tilt and swivel adjustment (pole size: 38-52mm)	
Reflector Material	Aluminum	
Ingress Protection	IP54 (outdoor)	
Radome Material	ABS (UV Stabilized)	
Operating Temperature (°C)	-40 to +65	

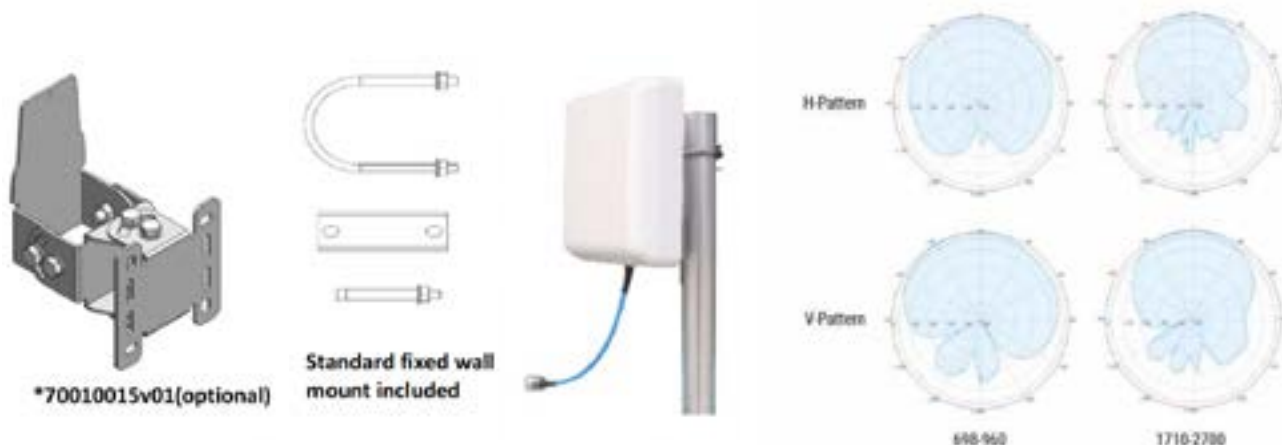

80012323

Outdoor
Panel Directional Antenna
VPol 1-port 3/8dBi
380-6000

Panel Outdoor 380-6000 3/8dBi

Type	80012323				
Frequency (MHz)	380-520	698-960	1710-2700	3300-4200	4900-6000
Gain (dBi)	3	6	8	7.5	8
VSWR	≤ 3.0	≤ 2.0	≤ 2.0	≤ 2.0	≤ 2.0
Polarization	Vertical				
PIM3 (dBc, @2x43dBm)	N/A	≤ -150			N/A
Front-to-Back Ratio (dB)	N/A	≥ 10	≥ 18	≥ 14	≥ 12
Horizontal Beamwidth (°)	110	90	65	40	14
Vertical Beamwidth (°)	80	65	60	36	18
Input Impedance (ohm)	50				
Max. Input Power (W)	50				
Lightning Protection	All metal parts of the antenna and mounting kit are DC grounded. Inner conductor is not DC grounded				
Connector	1 x 4.3-10 Female				
Dimension (mm)	315 x 195 x 68				
Weight (kgs)	Approx. 0.7				
Reflector Material	Aluminum				
Radome Material	ABS (UV Stabilized) RAL 90003				
Operating Temperature (°C)	-40 to +65				
Ingress protection	IP54 (outdoor or indoor) application				
Mounting	Wall mount plate included in the scope of the antenna				
Optional accessory (*order separately)	Universal Mounting Bracket 70010015v01 Wall mount: ±25° horizontal swivel & +27°/-35° vertical tilt Pole mount: ±45° horizontal swivel; pole size Ø38-Ø52mm				

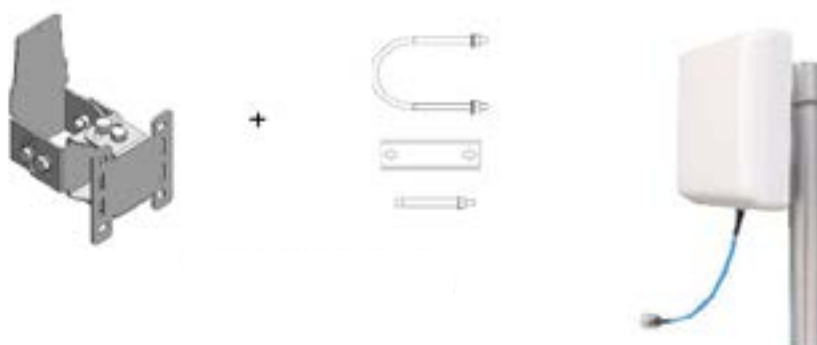

80013154

Outdoor
Directional Antenna
XXPol 4-port 8/9dBi
1695-4200MHz

Directional antenna 4 x 1695-4200Mhz 8/9dBi

Type	80013154	
Frequency Range (MHz)	1695-2700	3300-4200
Gain (dBi)	7.2	8.4
VSWR	≤ 1.8	≤ 2.0 (3300-3800) ≤ 2.5 (3800-4200)
Polarization	±45°	
PIM3 (dBc, @2x43dBm)	≤ -153	N/A
Isolation (dB)	≥ 23	≥ 20
Front-to-Back Ratio (dB)	≥ 15	≥ 15
Horizontal Beamwidth (°)	75	68
Vertical Beamwidth (°)	58	55
Input Impedance (ohm)	50	
Max. Input Power (W)	50	
Lightning Protection	DC grounded	
Connector	4 x 4.3-10 Female	
Dimension (mm)	315 x 195 x 68	
Weight (kgs)	Approx. 1.20	
Radome Material	ABS (UV Stabilized)	
Ingress protection	IP 54 (outdoor)	
Operating Temperature (°C)	-40 to +65	
Mounting	Fixed wall mounting bracket included	
Optional accessory (*order separately)	Universal Mounting Bracket 70010015v01 Wall mount: ±25° horizontal swivel & +27°/-35° vertical tilt Pole mount: ±45° horizontal swivel; pole size Ø38-Ø52mm	

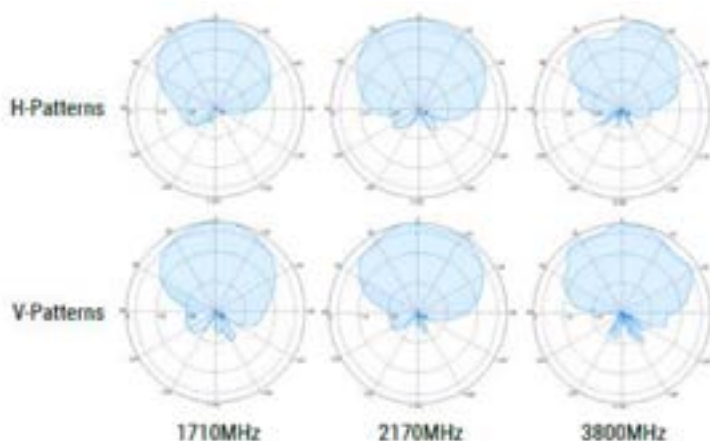
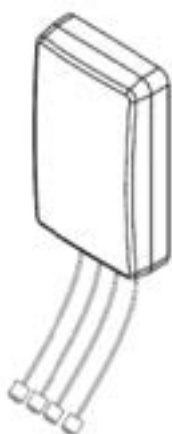

80013130

Outdoor
Directional Antenna
V/H-Pol 4-port 6/9dBi
698-4200MHz

Directional antenna 4 x 698-4200MHz 6/9dBi

Type	80013130		
Frequency (MHz)	698-960	1425-2700	3300-4200
Gain (dBi)	5.5	8.5	7.0
VSWR	≤ 2.0	≤ 2.0	≤ 2.0
Polarization	V-H		
PIM3 (dBc, @2x43dBm)	≤-153		
Isolation (dB)	≥ 12	≥ 20	≥ 24
Front-to-Back Ratio (dB)	≥ 7	≥13	≥10
Horizontal Beamwidth (°)	130-85	95-58	65-33
Vertical Beamwidth (°)	108-78	83-45	90-25
Input Impedance (ohm)	50		
Max. Input Power (W)	50		
Lightning Protection	All metal parts of the antenna and mounting kit are DC grounded. Inner conductor is not DC grounded		
Connector	4 x 4.3-10 Female		
Dimension (mm)	393 x 317 x 80		
Weight (kgs)	Approx. 1.74		
Reflector Material	Aluminum and RF-PCB		
Radome Material	ABS (UV Stabilized)		
Operating Temperature (°C)	-40 to +65		
Ingress protection	IP54 (outdoor or indoor)		
Mounting	Fixed wall mounting bracket included		
Optional accessory (*order separately)	Universal Mounting Bracket 70010015v01 Wall mount: ±25° horizontal swivel & +27°/-35° vertical tilt Pole mount: ±45° horizontal swivel; pole size Ø38-Ø52mm		



80112751

Directional Antenna
 X-Pol 2-port 8dBi 65°
 1710-2690 / 3300-4000
 Fixed Electrical D/T (0T)

XPOL Directional 1710-2690/ 3300-4000 8dBi 0°T

Type	80112751	
Frequency Range (MHz)	1710-2690	3300-4000
Gain (dBi)	8	8
VSWR	≤ 1.5	
3rd Order PIM (dBc)	≤ -150 @ 2x43dBm	
Polarization	±45°	
Electrical Tilt (°)	0	
Horizontal Beamwidth (°)	65 ±5	65 ±5
Vertical Beamwidth (°)	60 ±5	60 ±5
Input Impedance (ohm)	50	
Max. Input Power (W)	100	
Front-to-Back Ratio (dB)	≥ 23	
Isolation (dB)	≥ 25	
Lightning Protection	DC Grounded	
Connector Type	2 x 4.3-10 Female	
Dimension (mm)	220 x 160 x 80	
Weight (kgs)	1.0	
Radome Material	UV-PVC	
Ingress protection	IP56	
Reflector Material	Aluminum	
Rated Wind Velocity (km/h)	210	
Operating Temperature (°C)	-40 to +70	
Mounting	Mechanical Adjustable Downtilt Clamp for Pole Diameter 38-52 included	



80112752

Directional Antenna
 X-Pol 2-port 11dBi 65°
 1710-2690 / 3300-4000
 Fixed Electrical D/T (0T)

XPOL Directional 1710-2690/ 3300-4000 11dBi 0°T

Type	80112752	
Frequency Range (MHz)	1710-2690	3300-4000
Gain (dBi)	11	11
VSWR	≤ 1.5	
3rd Order PIM (dBc)	≤ -150 @ 2x43dBm	
Polarization	±45°	
Electrical Tilt (°)	0	
Horizontal Beamwidth (°)	65 ±5	65 ±5
Vertical Beamwidth (°)	30 ±5	30 ±5
Input Impedance (ohm)	50	
Max. Input Power (W)	100	
Front-to-Back Ratio (dB)	≥ 23	
Isolation (dB)	≥ 25	
Lightning Protection	DC Grounded	
Connector Type	2 x 4.3-10 Female	
Dimension (mm)	250 x 160 x 80	
Weight (kgs)	1.2	
Radome Material	UV-PVC	
Reflector Material	Aluminum	
Rated Wind Velocity (km/h)	210	
Operating Temperature (°C)	-40 to +70	
Mounting	Mechanical Adjustable Downtilt Clamp for Pole Diameter 38-52 included	



80112753

Outdoor
Directional Antenna
X-Pol 2-port 8/12dBi
698-3800

Directional outdoor 698-3800 8/12dBi

Type	80112753		
Frequency range (Mhz)	698-960	1710-2700	3300-3800
Gain (dBi)	8±1	11±1	12±1
Polarization	±45°		
VSWR	≤1.8		
Cross polar discrimination(dB)	≥15 (±60°≥8)		
PIM3 (dBc, @2x43dBm)	≤ -150		
Electrical downtilt	0°		
Front to back ratio(dB)	≥20		
Horizontal beamwidth	70±10	65±15	60±15
Vertical beamwidth	65±10	35±10	30±10
Isolation	≥25	≥20	≥20
Input Impedance (ohm)	50		
Max. Input Power (W)	100 (per port)		
Lightning Protection	DC Grounded		
Connector	2 x 4.3-10 Female		
Dimension (mm)	420*280*125		
Weight (kgs)	Approx. 3.8		
Connector position	Bottom		
Radome Material	UPVC / Gray		
Rated wind velocity	60m/s		
Operating Temperature (°C)	-40 to +65		
Suitable pole diameter(mm)	φ35-70		
Mechanical tilt(°)	0-15		
Mounting kit	Included		

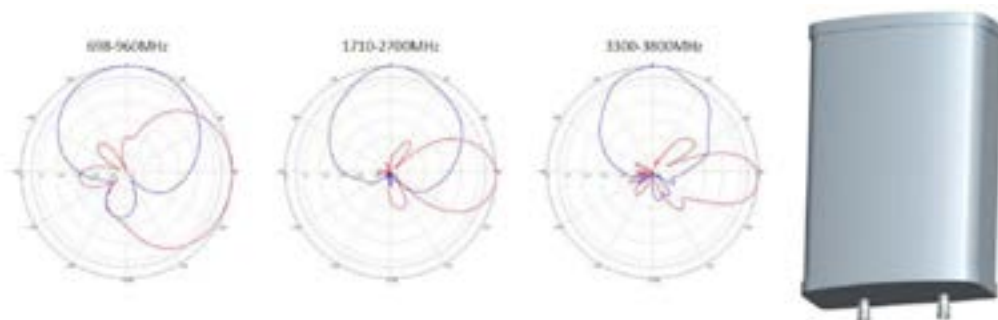

80112754

Directional Antenna
XX-Pol 4-port 8/9dBi
75°/65° 0T/0T

XXPol Directional
698-960/1710-2690/3300-4000 8/9dBi 0°T/0°T

698-960 / 1710-2690 / 3300-4000

Type	80112754		
Port	Port 1 & 2	Port 3 & 4	
Frequency Range (MHz)	698-960	1710-2690	3300-4000
Gain (dBi)	8.3	9.7	10.5
VSWR	≤ 1.5		
3rd Order PIM (dBc)	≤ -150 @ 2x43dBm		
Polarization	±45°		
Electrical Tilt (°)	0		
Horizontal Beamwidth (°)	75	65	65
Vertical Beamwidth (°)	63	60	60
Input Impedance (ohm)	50		
Max. Input Power (W)	100 (per port)		
Front-to-Back Ratio (dB)	≥ 20	≥ 23	
Isolation (dB)	≥ 25		
Lightning Protection	DC Grounded		
Connector Type	4 x 4.3-10 Female		
Dimension (mm)	330 x 280 x 130		
Weight (kgs)	2.5		
Radome Material	UV-PVC (GREY RAL7035)		
Reflector Material	Aluminum		
Rated Wind Velocity (km/h)	210		
Operating Temperature (°C)	-40 to +65		
Mounting	Mechanical Adjustable Downtilt Clamp for Pole Diameter 38-52 included		

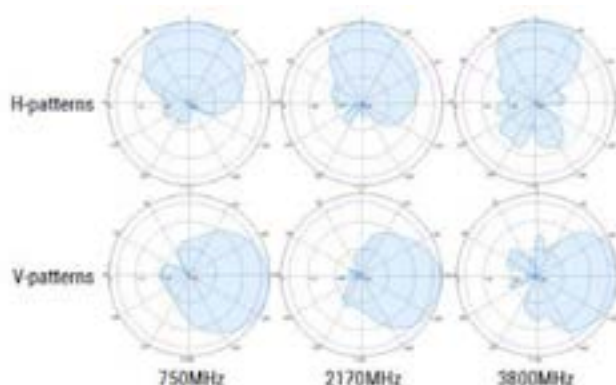

80012065

Stadium antenna
698-960/1710-3800Mhz
X-Pol 2-port 13/13/13dBi
38°/37°/33°

Narrow beam antenna
698-960/1710-3800Mhz

Type	80012065		
Frequency Range (MHz)	698-960	1710-2700	3300-3800
Gain (dBi)	12.5	13	13
VSWR	≤2.0	≤2.0	≤2.0
Polarization	±45°		
PIM3 (dBc, @2x43dBm)	≤ -150		
Horizontal Beamwidth (°)	38±6	37±6	33±6
Vertical Beamwidth (°)	38±6	36±6	32±6
Front-to-Back Ratio (dB)	≥18	≥16	≥16
Isolation (dB)	≥20	≥24	≥24
Input Impedance (ohm)	50		
Max. Input Power (W)	100W		
Lightning Protection	DC grounded		
Connectors	2 x 4.3-10 Female		
Dimension (mm)	456 x 422 x 131		
Weight (kgs)	Antenna 6kg Bracket 1.80kg		
Ingress protection Class	IP65		
Wind Load (N) @ 150km/h wind speed	Frontal: 253.85 Lateral: 85.51 Rearside: 296.15		
Radome Material	UV-PVC		
Reflector Material	Aluminium		
Max wind velocity (km/h)	210		
Operating Temperature (°C)	-40 to +65		
Mounting	Pole Mount (Pole Size: Ø50- Ø80mm)		

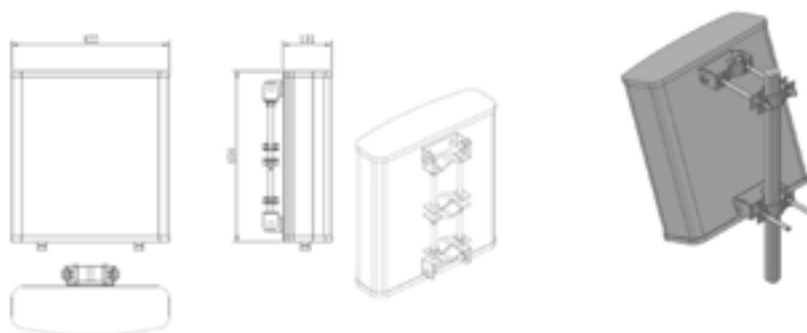

80020449v01

Outdoor Panel
 Directional Antenna
 VPol 1-port 5/6dBi -150dBc
 Bi-directional 694-3800MHz

V-Pol Bi-Directional 694-3800 5/6dBi

Type	80020449v01		
Frequency (MHz)	698-960	1710-2690	3300-4000
Gain (dBi)	4.5	5.2	6.6
VSWR	≤ 2.0	≤ 1.8	≤ 2.0
Polarization	Vertical		
PIM3 (dBc, @2x43dBm)	≤ -150		
Horizontal Beamwidth (°)	90 ± 10	75 ± 10	58 ± 10
Vertical Beamwidth (°)	75	60	50
Input Impedance (ohm)	50		
Max. Input Power (W)	100		
Lightning Protection	DC Grounded		
Connector (at the bottom)	1 x 4.3-10 Female		
Dimension (mm)	340 x 190 x 82		
Weight (kgs)	Approx. 1.0		
Radome Material	ASA + PC (White, RAL 9003)		
Operating Temperature (°C)	-40 to +65		
Mounting	Mounting Clamp for Pole Size Ø38 to Ø52 Included		

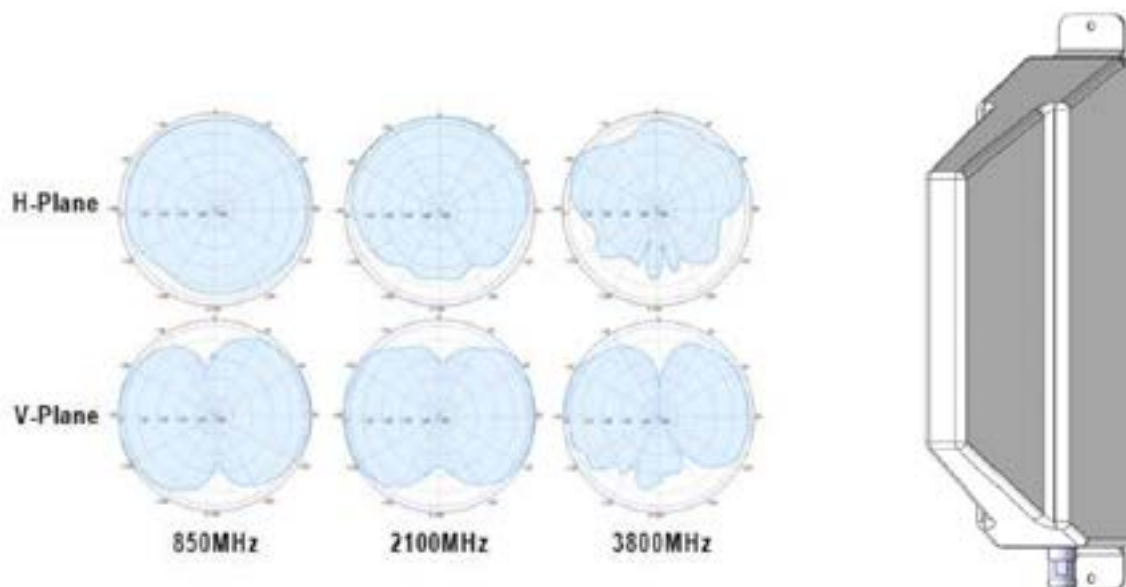

80011847

Outdoor Mini Omni Directional
Antenna V-Pol
1-port 3dBi
698-960 / 1710-4000

Outdoor Mini Omni
698-960/1710-4000 3dBi

Type	80011847				
Frequency (MHz)	698-806	806-960	1710-2170	2170-2700	3300-4000
Gain (dBi)	≥ 2.9	≥ 3.0	≥ 2.6	≥ 3.2	≥ 2.7
VSWR	≤ 2.5	≤ 2.5	≤ 3.0	≤ 2.5	≤ 1.5
Polarization	Vertical				
PIM3 (dBc, @2x43dBm)	≤ -150				
Horizontal Beamwidth (°)	360				
Vertical Beamwidth (°)	85	70	50	35	33
Input Impedance (ohm)	50				
Max. Input Power (W)	100				
Connector	1 x 4.3-10 Female				
Dimension (mm)	Ø30 x 200				
Weight (kgs)	Approx. 0.25				
Reflector Material	Aluminum				
Radome Material	Fiber Glass				
Operating Temperature (°C)	-40 to +65				
*Optional Mounting bracket	73410007 (order separately)				

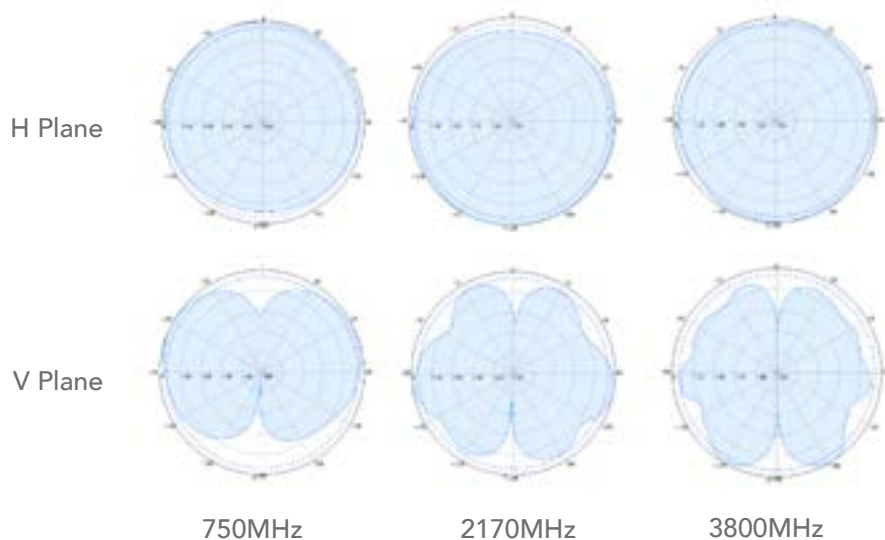

80020452

Outdoor Panel
Bidirectional Antenna
VHPol 2-port 5/6dBi -153dBc
Bi-directional 1710-4000MHz

VH-Pol Bi-Directional 1710-4000 5/6dBi

Type	80020452	
Frequency Range (MHz)	1710-2700	3300-4000
Gain (dBi)	5.5 ± 0.5	6 ± 0.5
VSWR	≤ 1.8	≤ 2.0
Polarization	Vertical/ Horizontal	
PIM3 (dBc, @2x43dBm)	≤ -153	
Horizontal Beamwidth (°)	120	108
Vertical Beamwidth (°)	51	52
Isolation (dB)	24	3300-3800 (24) 3800-4000 (20)
Input Impedance (ohm)	50	
Max. Input Power (W)	100	
Lightning Protection	DC Grounded	
Connector (at the bottom)	2 x 4.3-10 Female	
Dimension (mm)	340 x 190 x 82	
Weight (kgs)	Approx. 1.2	
Radome Material	ASA + PC (White, RAL 9003)	
Operating Temperature (°C)	-40 to +65	
Mounting	Wall Mount with 2 x M6*60 Expansion Bolt	

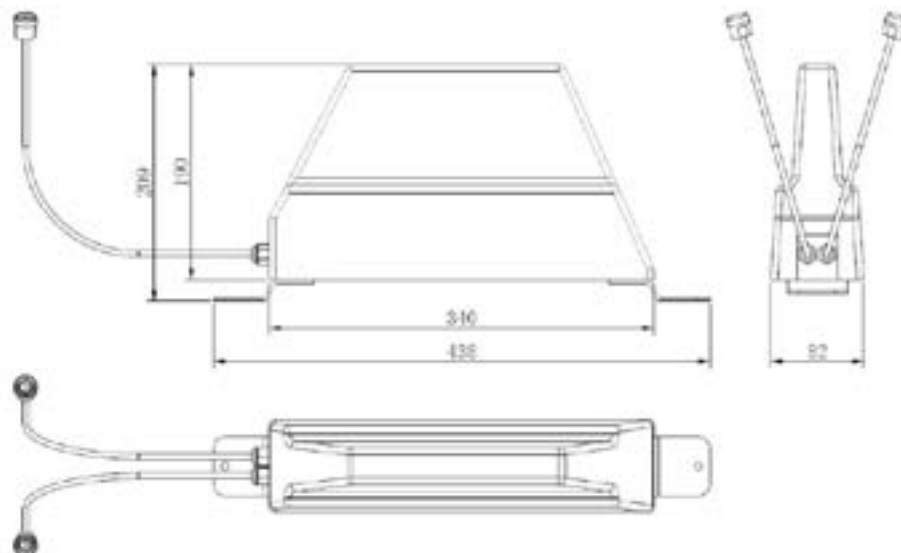

73410007

Mounting bracket
for mini omni antenna 80011847
Suitable for wall
mount and pole mount

Mount Bracket for Mini Omni Antenna

Type	73410007
Applicable Antenna Models	80011847
Installation Scenarios	<p>Pole Mount: with two U-clamps provided for pole size 25 – 45mm</p> <p>Wall Mount: fix through the four holes with screws (screws not included, screw type depends on wall material)</p>
Material	Stainless Steel (thk = 2mm)
Attaching of the Antenna	<ol style="list-style-type: none"> 1. Remove the fastening nut from the bottom of the antenna 2. Insert the antenna through the centre hole of the bracket 3. Tighten the fastening nut from the bottom 4. Apply thread adhesive or sealant when necessary for better results 5. Attach the signal cable to the bottom connector of the antenna 6. Only attach the antenna to the bracket after the bracket is fixed on the wall/ pole
Dimensions (mm)	89 x 80 x 60

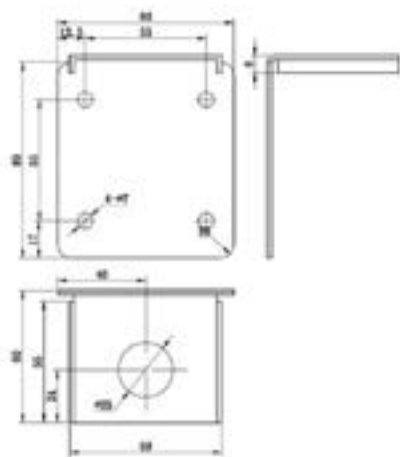

70010015v01

Universal Mounting Bracket
For 1-port / 2-port / 4-port
Small Panel Antenna
Horizontal and Vertical Adjustments

Type	70010015v01
Application	For mounting 1-port, 2-port, or 4-port small panel antennas Suitable for wall mount and pole mount
Material	2.0mm Stainless Steel
Tilt Adjustment	Up to 45° (Both horizontal and vertical, depending on antenna size.)
Mounting (Included in the Packing)	Wall mount: secure the bracket with expansion bolts supplied. Pole mount: attach the bracket to the pole with the U-clamps supplied. Insert the antenna on the flap of the bracket and secure M3 screw on the flap. Adjustment to desire horizontal / vertical angle.
Size (reference only)	126 x 80 x 95mm
Accessories Included	M6 x 60mm Expansion Bolts x 4 (Wall Mount) U-Clamps x 2 (Pole Size: Ø38-52mm) M3 x 6mm Allen Screw x 1

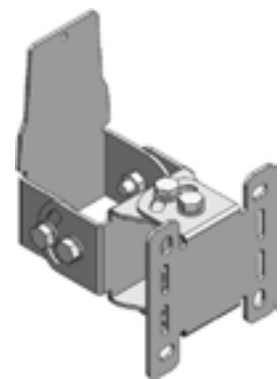
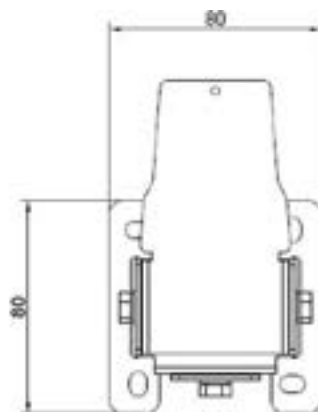
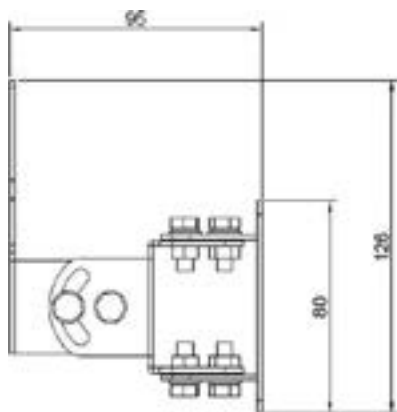

Universal Bracket 70010015V0:

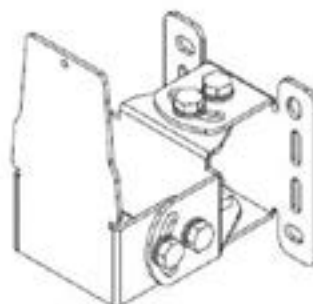
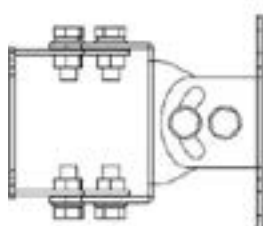

Accessories included



Multiband combiners

Multiband combiners are used to isolate two or more channels on different frequencies, thus allowing the common use of one antenna by several transmitters or receivers. Very low insertion loss, excellent signal isolation and superior intermodulation properties prevent mutual interference between adjacent systems. All diplexers, triplexers and quadruplexers, pentaplexers and hexaplexers are suited for indoor and outdoor installation. ESB designs and manufactures combiners under strict quality control with VSWR and PIM values in line with today's demanding 5G networks. Both versions (single and dual) are available with mainly 4.3-10 connectors but also N female connector.

Part Number	Description	Page
78210264	DBC 50-2200/2400-2500MHz N(f) SU	120
728956	DBC 68-470/870-970MHz N(f) SU	122
728959	DBC 68-470/698-2700MHz N(f) SU	123
78321001v01	DBC 698-2700/3300-4000MHz 4.3-10 SU	124
78322001v01	DBC 698-2700/3300-4000MHz 4.3-10 DU	124
78321002	DBC 1710-1880/1920-2700MHz 4.3-10 SU	125
78322002	DBC 1710-1880/1920-2700MHz 4.3-10 DU	125
78331004	TBC 703-788 / 791-862 / 880-960 4.3-10 SU	126
78332004	TBC 703-788 / 791-862 / 880-960 4.3-10 DU	126
78331002	TBC 690-960/1710-2700/3300-3800MHz 4.3-10 SU	128
78332002	TBC 600-960/1710-2700/3300-3800MHz 4.3-10 DU	128
78331003	TBC 703-788/791-960/1427-3800MHz 4.3-10 SU	130
78332003	TBC 703-788/791-960/1427-3800MHz 4.3-10 DU	130
78341001	QBC 1695-1880/1920-2200/2300-2700/3300-3800MHz 4.3-10 SU	132
78342001	QBC 1695-1880/1920-2200/2300-2700/3300-3800MHz 4.3-10 DU	132
78341004	QBC 380-470 / 698-862 / 880-960 & 1710-2170 / 3300-3800 SU	134
78342004	QBC 380-470 / 698-862 / 880-960 & 1710-2170 / 3300-3800 DU	134
78351001	PBC 690-862/880-960/1710-1880/1920-2170/2490-2690MHz 4.3-10 SU	136
78352001	PBC 690-862/880-960/1710-1880/1920-2170/2490-2690MHz 4.3-10 DU	136
78351002	PBC 690-960/1710-1880/1920-2170/2500-2700/3300-3800MHz 4.3-10 SU	138
78352002	PBC 690-960/1710-1880/1920-2170/2500-2700/3300-3800MHz 4.3-10 DU	138
78361001	HBC 600-960/1695-1880/1920-2200/2300-2400/2500-2690/3300-3800MHz 4.3-10 SU	140
78362001	HBC 600-960/1695-1880/1920-2200/2300-2400/2500-2690/3300-3800MHz 4.3-10 DU	140

78210264

Dual Band Combiner 50-2200 / 2400-2500Mhz

Dual Band Combiner
50-2200 / 2400-2500

Type	78210264 Single Unit
Frequency (MHz) Band 1 Band 2	50-2200 2400-2500
Insertion Loss (dB)	Port1-3: < 0.1 dB (50 – 2200 MHz) Port2-3: < 0.2 dB (2400 – 2500 MHz)
Isolation (dB)	≥ 50
PIM3 (dBc, @2x43dBm)	≤ -150
VSWR	< 1.25 (50 – 2200 / 2400 – 2500 MHz)
Input Impedance (ohm)	50
Max. Input Power (W)	200 per Port
DC/AISG transparency Port 1 ↔ Port 3 Port 2 ↔ Port 3	DC By-pass (max 2500mA) Built-in DC Stop
Connectors	N Female
Dimension (mm)*	86 mm x 30.4 mm x 181.4 mm (including connectors and mounting feet)
Weight (kgs)	Approx 0.5
Ingress Protection Class	Indoor
Operational RH (%)	≤ 95
Operating Temperature (°C)	-30 to +60
Storage Temperature (°C)	-40 to +85



Dimensions

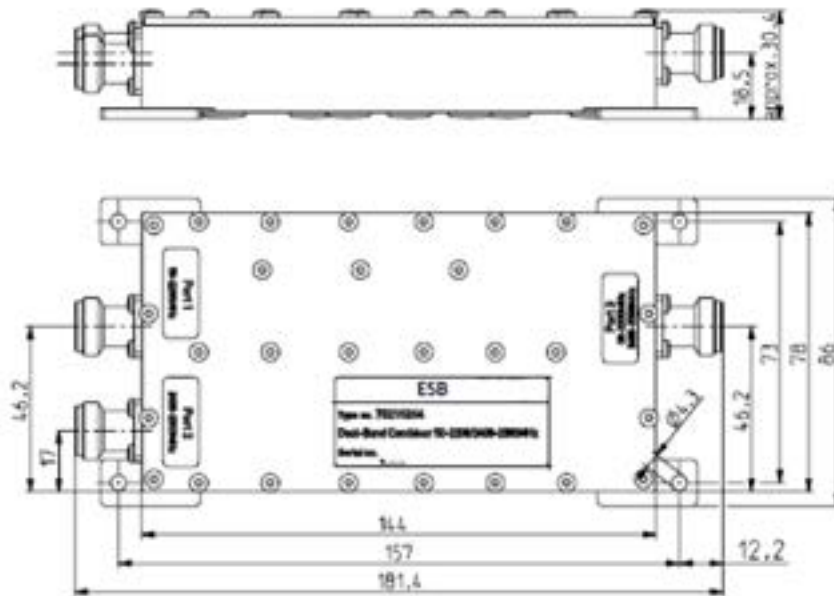

Block Diagram

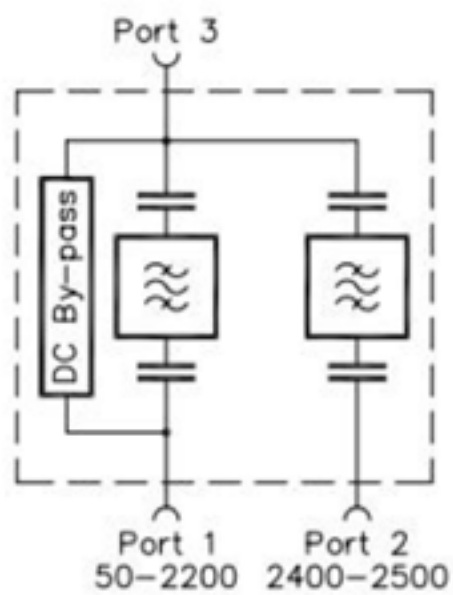

728956

Dual Band combiner 68-470/870-970MHz

Dual-band combiner
68-470/870-970Mhz

Type	728956
Frequency (MHz) Band 1 Band 2	68-470 870-970
Insertion Loss (dB)	≤ 0.5
Isolation (dB)	≥ 45
Input Impedance (ohm)	50
Max. Input Power (W)	50 per Port
Connectors	N Female
Dimension (mm)	152 x 120 x 37
Weight (kgs)	1.2
Ingress Protection Class	IP65
Operational RH (%)	≤ 95
Operating Temperature (°C)	-20 to +70
Storage Temperature (°C)	-40 to +85

Dimensions

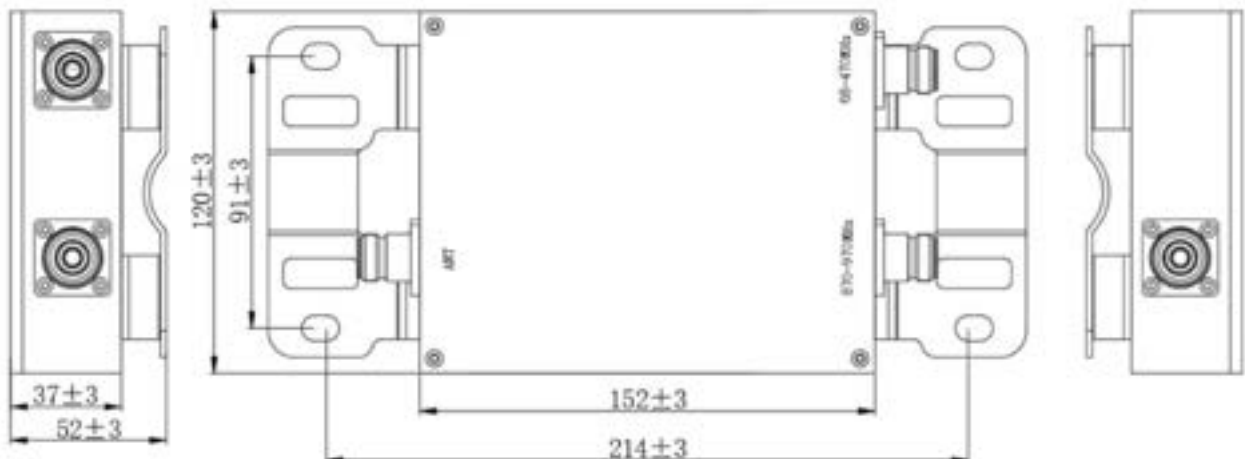

728959

Dual Band Combiner 68-470 / 698-2700

Dual Band Combiner
68-470 / 698-2700

Type	728959
Frequency (MHz) Band 1 Band 2	68-470 698-2700
Insertion Loss (dB)	≤ 0.5
Isolation (dB)	≥ 40
VSWR	1.4
Input Impedance (ohm)	50
Max. Input Power (W)	50 per Port
Connectors	N Female
Dimension (mm)	188 x 142 x 44
Weight (kgs)	TBD
Ingress Protection Class	IP65
Operational RH (%)	≤ 95
Operating Temperature (°C)	-20 to +75
Storage Temperature (°C)	-40 to +85

Dimensions

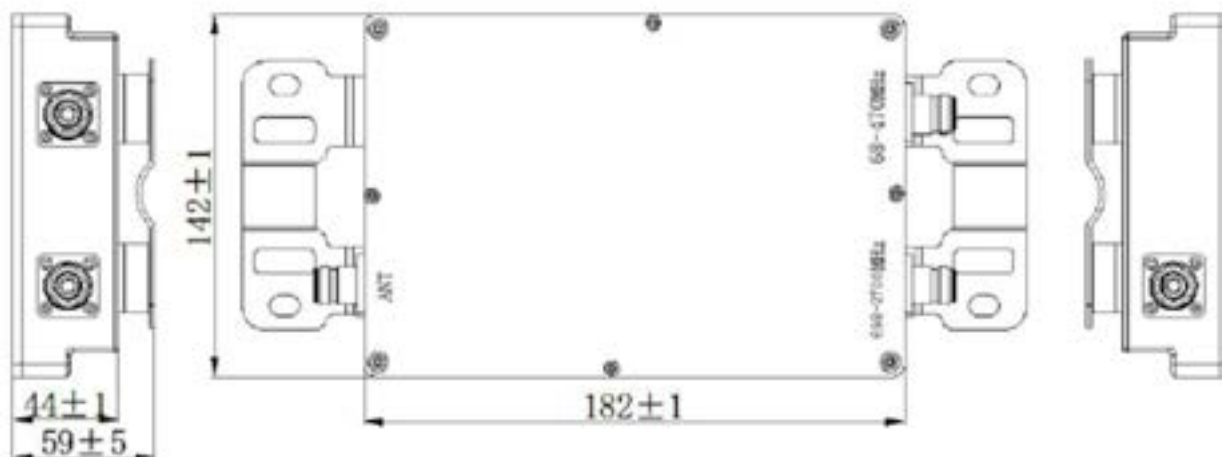

7832x001v01

Dual Band Combiner 690-2700 / 3300-4000

Dual Band Combiner
690-2700 / 3300-4000

Type	78321001v01 Single Unit	78322001v01 Double Unit
Frequency (MHz) Band 1 Band 2	690-2700 3300-4000	
Insertion Loss (dB)	≤ 0.5	
Isolation (dB)	≥ 50	
PIM3 (dBc, @2x43dBm)	≤ -160	
Input Impedance (ohm)	50	
Max. Input Power (W)	200 per Port	
ASIG/DC By-pass	Bypass at Band 1 (690-2700)	Stop at Band 2 (3300-4000)
Connectors	4.3-10 Female	
Dimension (mm)*	170 x 91 x 42	170 x 91 x 84
Weight (kgs)	1.2	2.4
Ingress Protection Class	IP67	
Operational RH (%)	≤ 95	
Operating Temperature (°C)	-30 to +60	
Storage Temperature (°C)	-40 to +85	
Lightning Protection	10kA@8/20µs	
Mounting	Wall Mount or Pole Mount (Pole Size: Ø35-125mm)	



7832x002**Dual Band Combiner
1710-1880 / 1920-2700**Dual Band Combiner
1710-1880 / 1920-2700

Type	78321002 Single Unit	78322002 Double Unit
Frequency (MHz) Band 1 Band 2	1710-1880 1920-2700	
Insertion Loss (dB)	≤ 0.5	
Isolation (dB)	≥ 50	
PIM3 (dBc, @2x43dBm)	≤ -160	
Input Impedance (ohm)	50	
Max. Input Power (W)	200 per Port	
ASIG/DC By-pass	Bypass	
Connectors	4.3-10 Female	
Dimension (mm)*	132 x 116 x 44	132 x 116 x 88
Weight (kgs)	1.8	3.8
Ingress Protection Class	IP67	
Operational RH (%)	≤ 95	
Operating Temperature (°C)	-30 to +60	
Storage Temperature (°C)	-40 to +85	
Lightning Protection	3kA@10/350µS	
Mounting	Wall Mount or Pole Mount (Pole Size: Ø35-125mm)	



7833x004

Triple Band Combiner 703-788 / 791-862 / 880-960

Triple Band Combiner
703-788 / 791-862 / 880-960

Type	78331004 Single Unit	78332004 Double Unit
Frequency (MHz) Band 1 Band 2 Band 3	703-788 791-862 880-960	
Insertion Loss (dB)	Port 1: ≤ 0.5 dB (703-780)/ ≤ 1.0 (780-787)/ ≤ 1.5 (787-788) Port 2: ≤ 1.5 dB (791-792)/ ≤ 1.0 (792-794)/ ≤ 0.5 (794-862) Port 3: ≤ 0.5 (880-960)	
Isolation (dB)	≥ 40	
PIM3 (dBc, @2x43dBm)	≤ -160	
VSWR	≤ 1.25	
Input Impedance (ohm)	50	
Max. Input Power (W)	200 per Port	
ASIG/DC By-pass	Bypass at All Ports	
Connectors	4.3-10 Female	
Dimension (mm)*	TBD	TBD
Weight (kgs)	TBD	TBD
Ingress Protection Class	IP66	
Operational RH (%)	≤ 95	
Operating Temperature (°C)	-40 to +65	
Storage Temperature (°C)	-50 to +85	
Barometric Pressure (kPa)	TBD	
Mounting	Wall Mount or Pole Mount (Pole Size: Ø35-125mm)	

Dimensions

Double unit 78332004

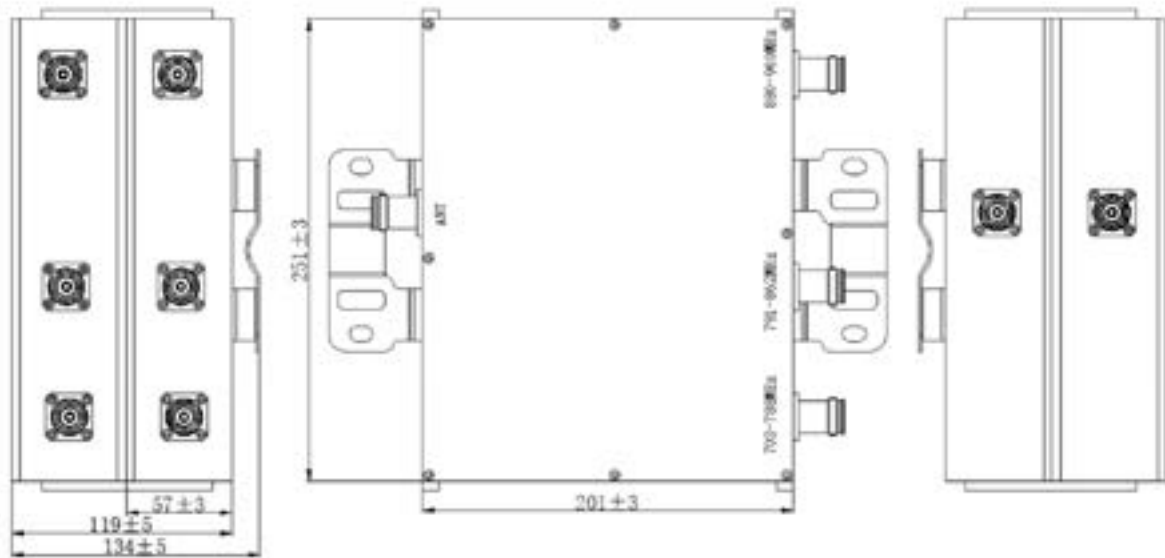

Single unit 78331004

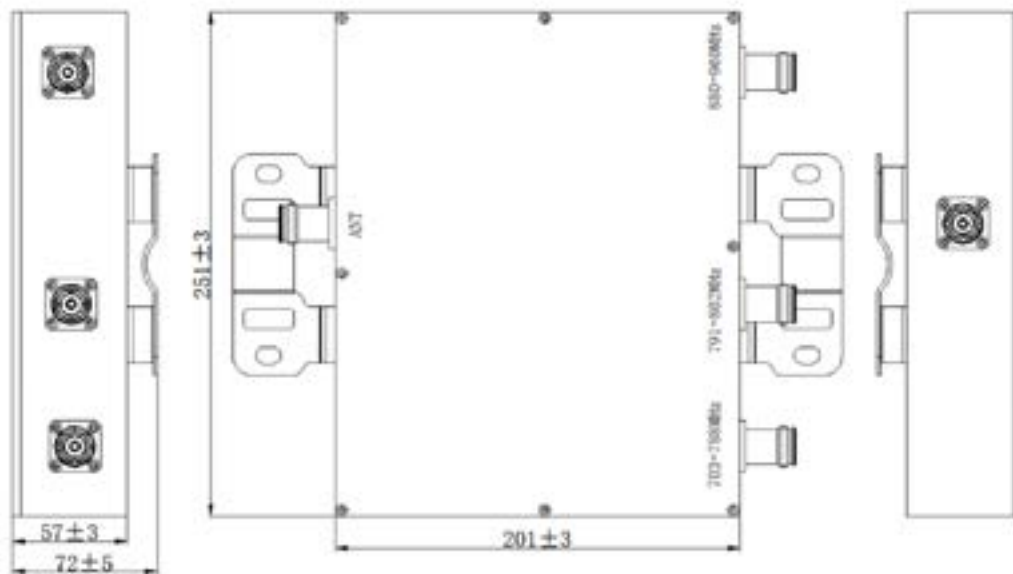

7833x002

Triple Band Combiner 600-960 / 1710-2700 / 3300-3800

Triple Band Combiner
600-960 / 1710-2700 / 3300-3800

Type	78331002 Single Unit	78332002 Double Unit
Frequency (MHz)		
Band 1	600-960	
Band 2	1710-2700	
Band 3	3300-3800	
Insertion Loss (dB)	≤ 0.5	
Isolation (dB)	> 70	
PIM3 (dBc, @2x43dBm)	≤ -160 (690-2700) ≤ 155 (3300-3800)	
VSWR	≥ 20	
Input Impedance (ohm)	50	
Max. Input Power (W)	250 per Port	
ASIG/DC By-pass	Bypass at All Ports	
Connectors	4.3-10 Female	
Dimension (mm)*	165 x 154 x 52	165 x 154 x 107
Weight (kgs)	2.2	4.4
Ingress Protection Class	IP67	
Operational RH (%)	≤ 95	
Operating Temperature (°C)	-40 to +65	
Lightning Protection	IEC 61000-4-5: 3kA @ 10/350µs / 10kA @ 8/20µs	
Storage Temperature (°C)	-50 to +85	
Barometric Pressure (kPa)	10kA@8/20µS	
Mounting	Wall Mount or Pole Mount (Pole Size: Ø35-125mm)	

Dimensions

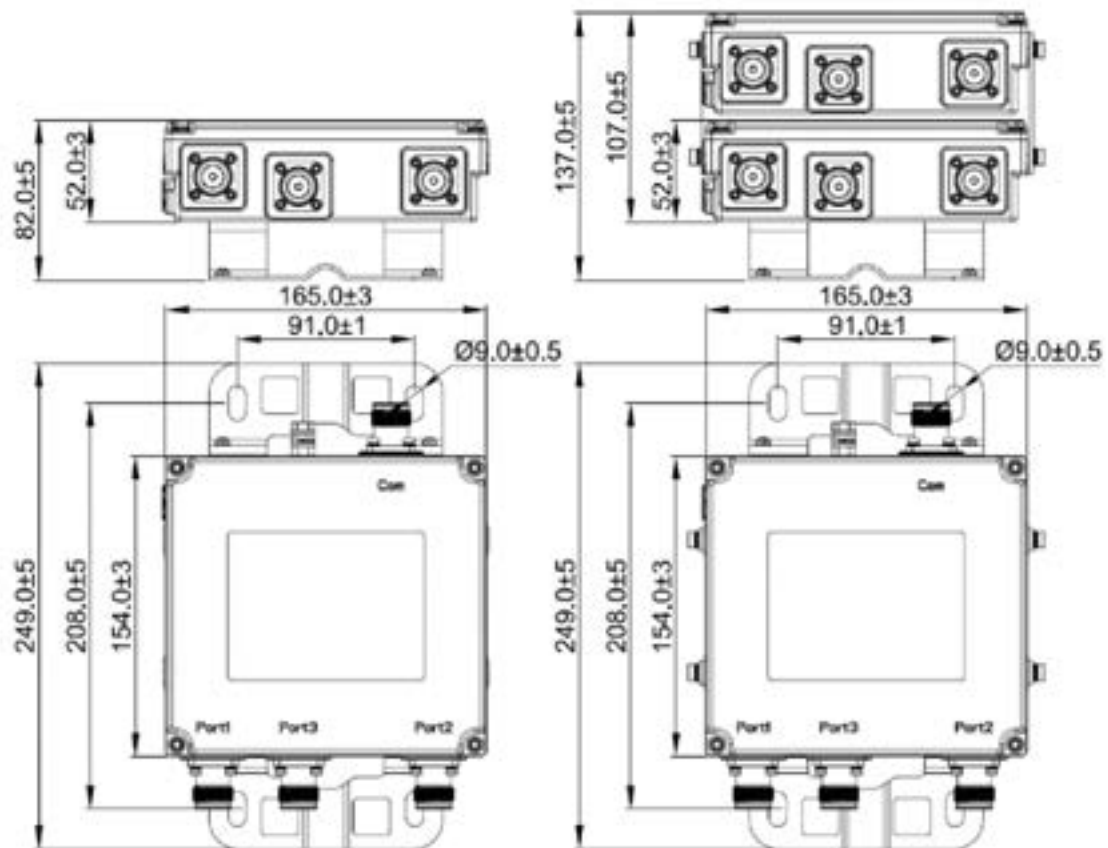

7833x003

Triple Band Combiner 703-788 / 791-960 / 1427-3800

Triple Band Combiner
703-788 / 791-960 / 1427-3800

Type	78331003 Single Unit	78332003 Double Unit
Frequency (MHz) Port 1 Port 2 Port 3	703-788 791-960 1427-3800	
Insertion Loss (dB)	Port 1: ≤ 0.7 (703-785) / ≤ 1.0 (785-787) / ≤ 1.5 (787-788) Port 2: ≤ 1.5 (791-792) / ≤ 1.0 (792-800) / ≤ 0.7 (800-960) Port 3: ≤ 0.3 (1427-3800)	
Isolation (dB)	≥ 40	
PIM3 (dBc, @2x43dBm)	≤ -160	
VSWR	≤ 1.25	
Input Impedance (ohm)	50	
Max. Input Power (W)	Port 1: 200 Port 2: 200 Port 3: 200 (1427-2700) / 100 (2700-3800)	
ASIG/DC By-pass	Bypass at Port 2 (Max. 2500mA)	
Connectors	4.3-10 Female	
Dimension (mm)*	260 x 300 x 88	260 x 300 x 181
Weight (kgs)	6.2	12
Ingress Protection Class	IP66	
Operational RH (%)	≤ 95	
Operating Temperature (°C)	-40 to +60	
Storage Temperature (°C)	-40 to +85	
Barometric Pressure (kPa)	55 to 106	
Mounting	Wall Mount	

Dimensions

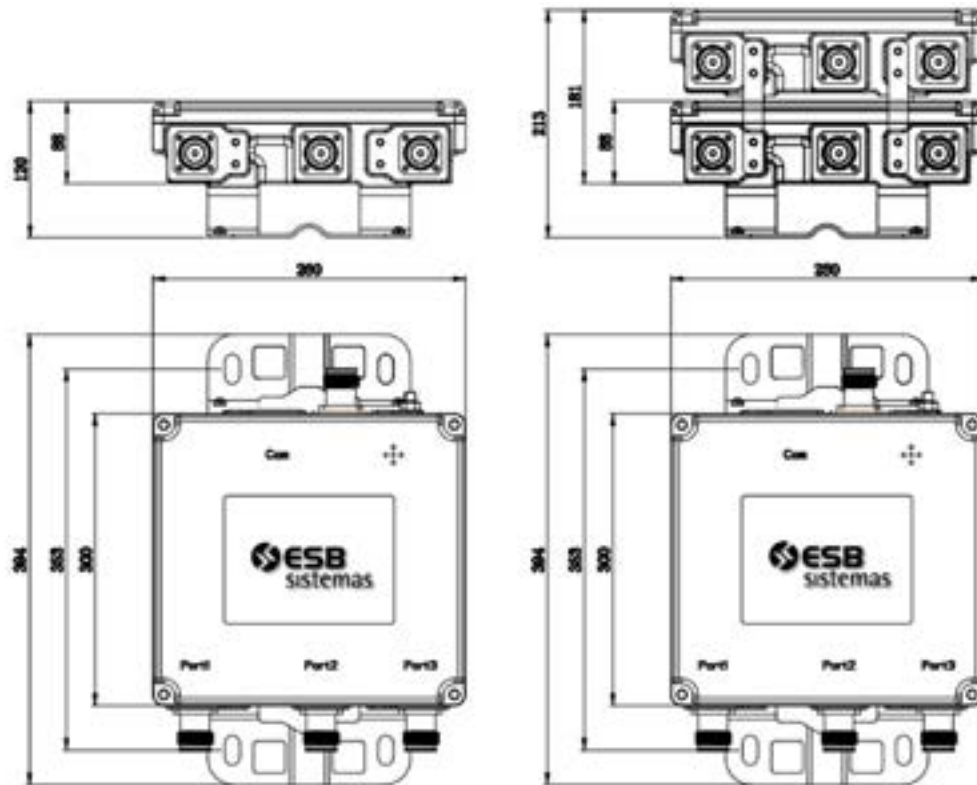

Block Diagram

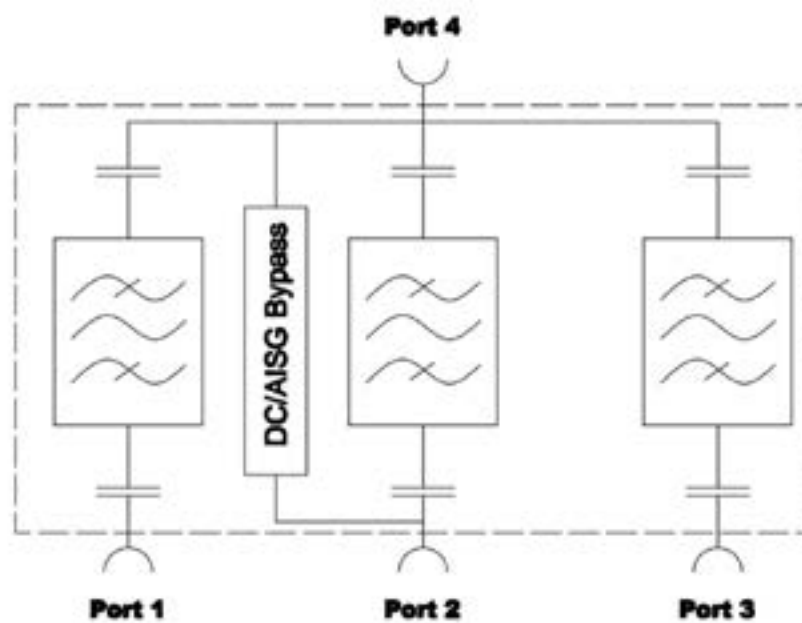

7834x001

Quad Band Combiner
1695-1880 / 1920-2200 / 2300-2700 /
3300-3800

Quad Band Combiner
 1695-1880 / 1920-2200 / 2300-
 2700 / 3300-3800

Type	78341001 Single Unit	78342001 Double Unit
Frequency (MHz)		
Band 1	1695-1880	
Band 2	1920-2200	
Band 3	2300-2700	
Band 4	3300-3800	
Insertion Loss (dB)	≤ 0.3	
Isolation (dB)	> 50	
PIM3 (dBc, @2x43dBm)	≤ -160	
Return Loss (dB)	≥ 20	
Input Impedance (ohm)	50	
Max. Input Power (W)	250 per Port	
ASIG/DC By-pass	Bypass at All Ports	
Connectors	4.3-10 Female	
Dimension (mm)*	208 x 188 x 53	208 x 188 x 111
Weight (kgs)	2.7	5.5
Ingress Protection Class	IP67	
Operational RH (%)	≤ 95	
Operating Temperature (°C)	-40 to +65	
Storage Temperature (°C)	-50 to +85	
Barometric Pressure (kPa)	10kA@8/20µS	
Mounting	Wall Mount or Pole Mount (Pole Size: Ø35-125mm)	

Dimensions

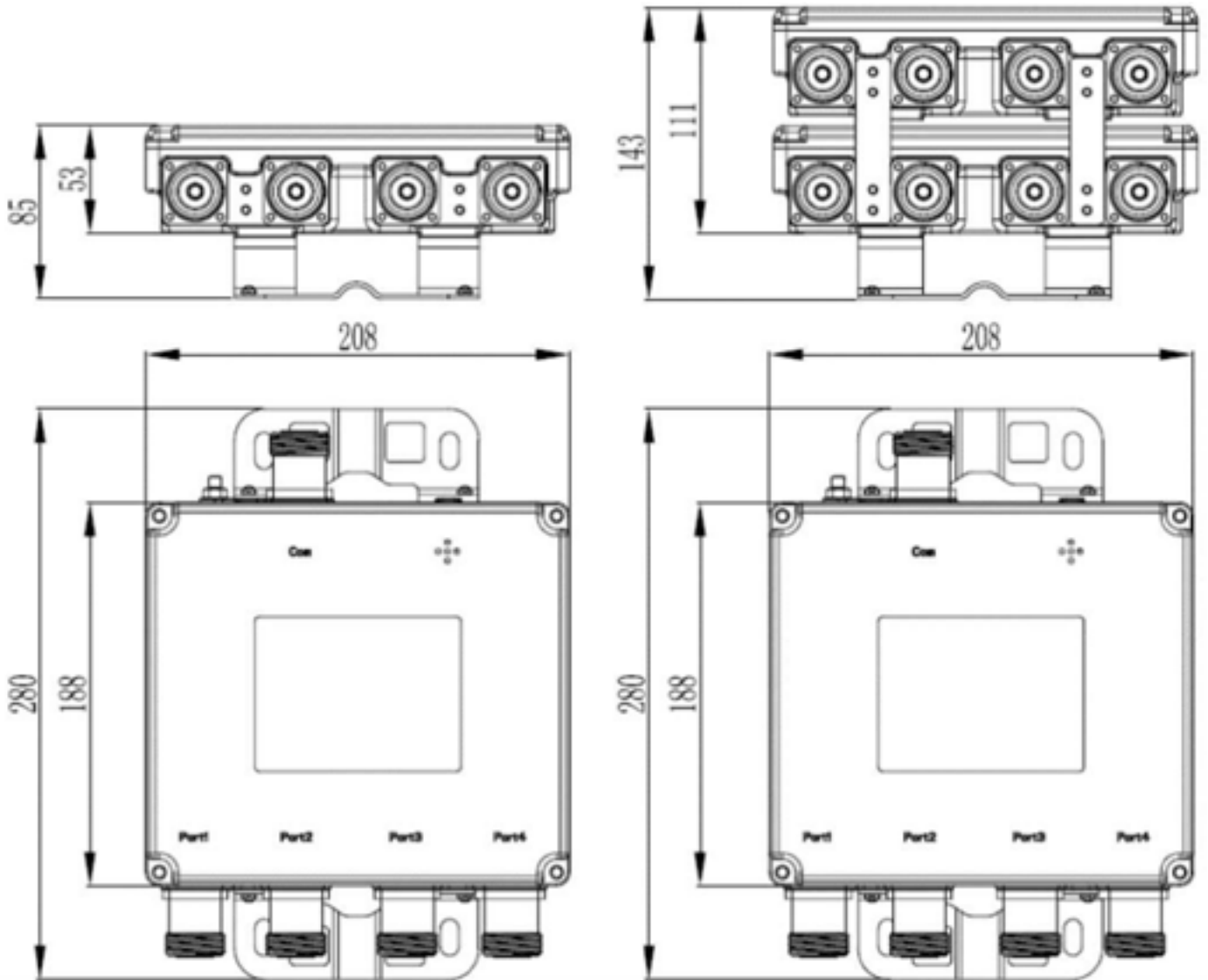

78341004

Quad Band Combiner
380-470 / 698-862 / 880-960 &
1710-2170 / 3300-3800

Quad Band Combiner
 380-470 / 698-862 /
 880-960 & 1710-
 2170 / 3300-3800

Type	78341004 Single Unit
Frequency (MHz)	
Band 1	380-470
Band 2	698-862
Band 3	880-960 & 1710-2170
Band 4	3300-3800
Insertion Loss (dB)	≤ 0.6
Isolation (dB)	>40
VSWR	≤1.4
PIM3 (dBc, @2x43dBm)	≤ -155
Input Impedance (ohm)	50
Power handling	100W (average) per port
ASIG/DC By-pass	Bypass (max 2500mA) all ports
Connectors	4.3-10 Female
Dimension (mm)*	205 x 320 x 62
Weight (kgs)	4.2
Ingress Protection Class	IP65
Operational RH (%)	≤ 95
Operating Temperature (°C)	-10 to +65
Storage Temperature (°C)	-50 to +85
Barometric Pressure (kPa)	5kA; 8/20 μs pulse
Mounting	Wall Mount or Pole Mount (Pole Size: Ø35-125mm)

Dimensions

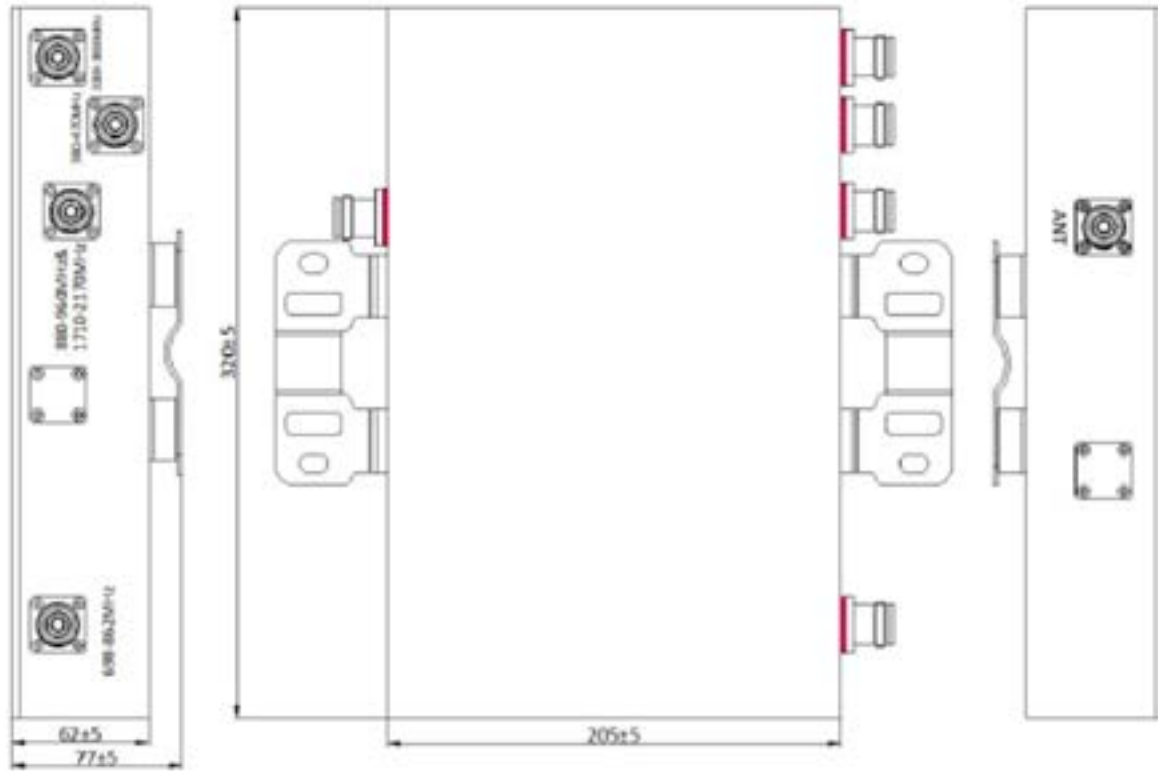

7835x001

Penta Band Combiner

Penta-Band Combiner
690-862 / 880-960 / 1710-1880 /
1920-2170 / 2490-2690

Designed for co-siting purposes | Can be used at the BTS side or the antenna side
Suitable for indoor and outdoor applications | Built-in lightning protection | Wall or pole mounting

Type	78351001 Single Unit	78352001 Double Unit
Frequency (MHz)		
Band 1	690-862	
Band 2	880-960	
Band 3	1710-1880	
Band 4	1920-2170	
Band 5	2490-2690	
Insertion Loss (dB)	≤ 0.5	
Isolation (dB)	≥ 50	
PIM3 (dBc, @2x43dBm)	≤ -155	
Input Impedance (ohm)	50	
Power Average (W)	150	
Return Loss	≥18dB	
Max. Input Power (W)	200W	
Peak Power (W)	1000W	
ASIG/DC By-pass	All ports	
Colour	Cool grey	
Connectors	4.3-10F	
Dimension (mm)*	317 x 190 x 59	317 x 190 x 123
Weight (kgs)	5kg	10kg
Ingress Protection Class	IP65	
Operational RH (%)	≤ 95	
Operating Temperature (°C)	-20 to +65	

Dimensions

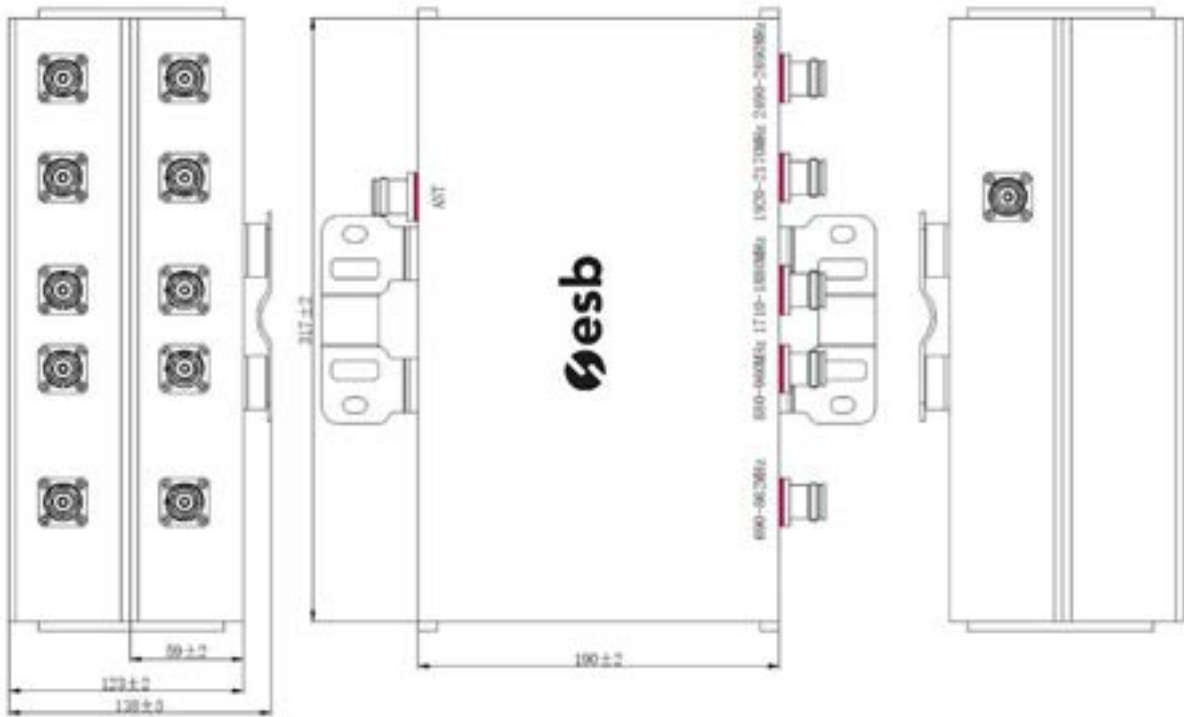

7835x002

Penta-Band Combiner
690-960/1710-1880/1920-
2170/2500-2700/3300-3800MHz

Penta Band Combiner

Type	78351002 Single Unit	78352002 Double Unit
Frequency (MHz)		
Band 1	690-960	
Band 2	1710-1880	
Band 3	1920-2170	
Band 4	2500-2700	
Band 5	3300-3800	
Insertion Loss (dB)	≤ 0.5	
Isolation (dB)	≥ 50	
PIM3 (dBc, @2x43dBm)	≤ -160	
Input Impedance (ohm)	50	
Power Average (W)	150	
Return Loss	≥18dB	
Max. Input Power (W)	≤ 500W	
Peak Power (W)	≤ 2000W	
ASIG/DC By-pass	All ports	
Colour	Cool grey	
Connectors	4.3-10F	
Dimension (mm)*	245 x 154 x 52	245 x 104 x 104
Weight (kgs)	3kg	6kg
Ingress Protection Class	IP65	
Operational RH (%)	≤ 95	
Operating Temperature (°C)	-20 to +65	

Accessories(order separately)

Type no.	Description
734365	Hose clamp



Dimensions

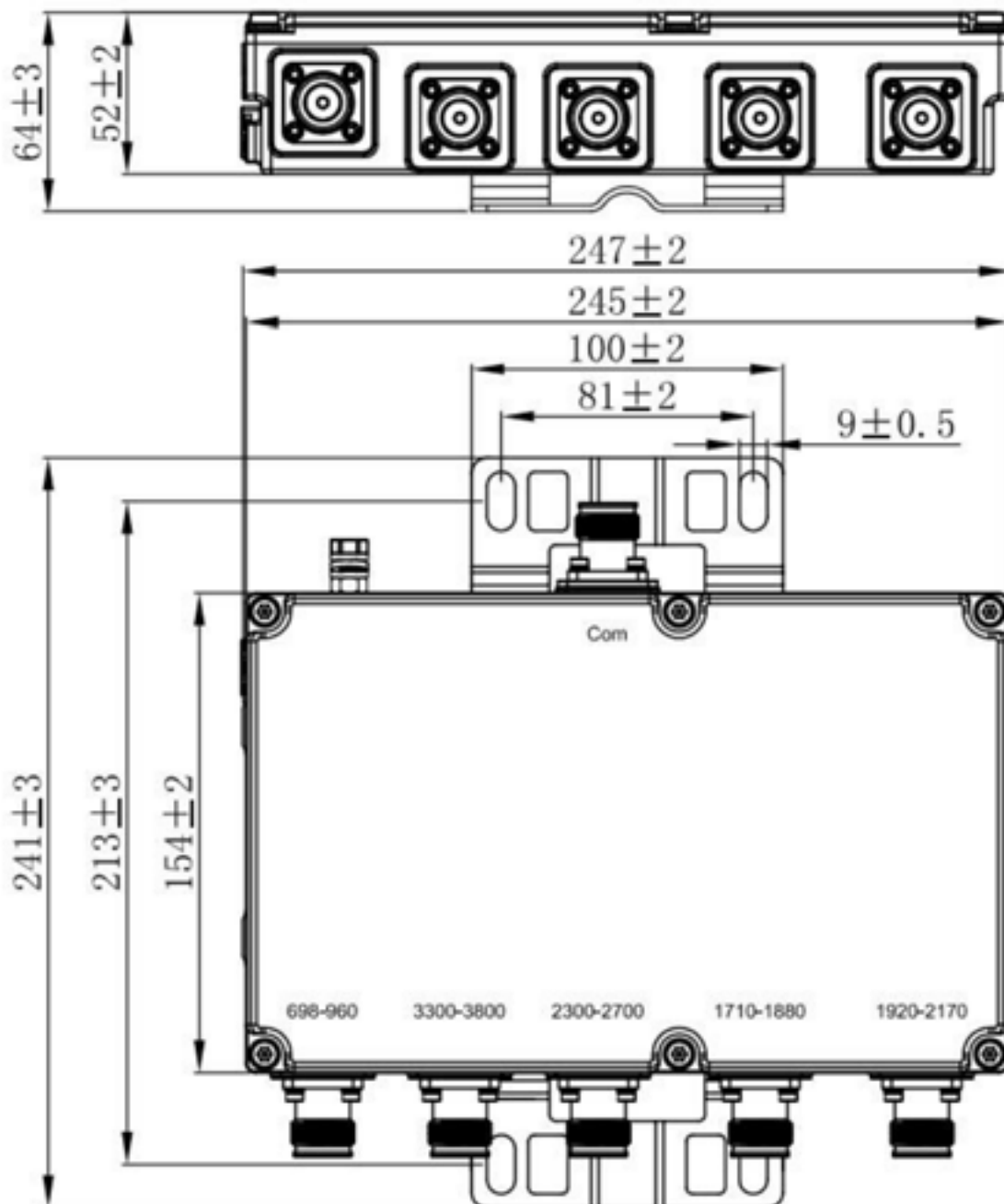

7836x001

Hexa-Band Combiner
 600-960 / 1695-1880 / 1920-2200/
 2300-2400 / 2500-2690 / 3300-3800

Hexa-Band Combiner

Type	78361001 Single Unit	78362001 Double Unit
Frequency (MHz)		
Band 1	600-960	
Band 2	1695-1880	
Band 3	1920-2200	
Band 4	2300-2400	
Band 5	2500-2690	
Band 6	3300-3800	
Insertion Loss (dB)	≤ 0.5	
Isolation (dB)	≥ 50	
PIM3 (dBc, @2x43dBm)	≤ -160	
Return Loss (dB)	≥ 19	
Input Impedance (ohm)	50	
Max. Input Power (W)	300	
Peak Power (W)	2,000	
ASIG/DC By-pass	NA	
Connectors	4.3-10F	
Dimension (mm)	281 x 196 x 58	281 x 196 x 123
Weight (kgs)	4.4	8.5
Ingress Protection Class	IP66	
Operational RH (%)	≤ 95	
Operating Temperature (°C)	-10 to +65	

Dimensions

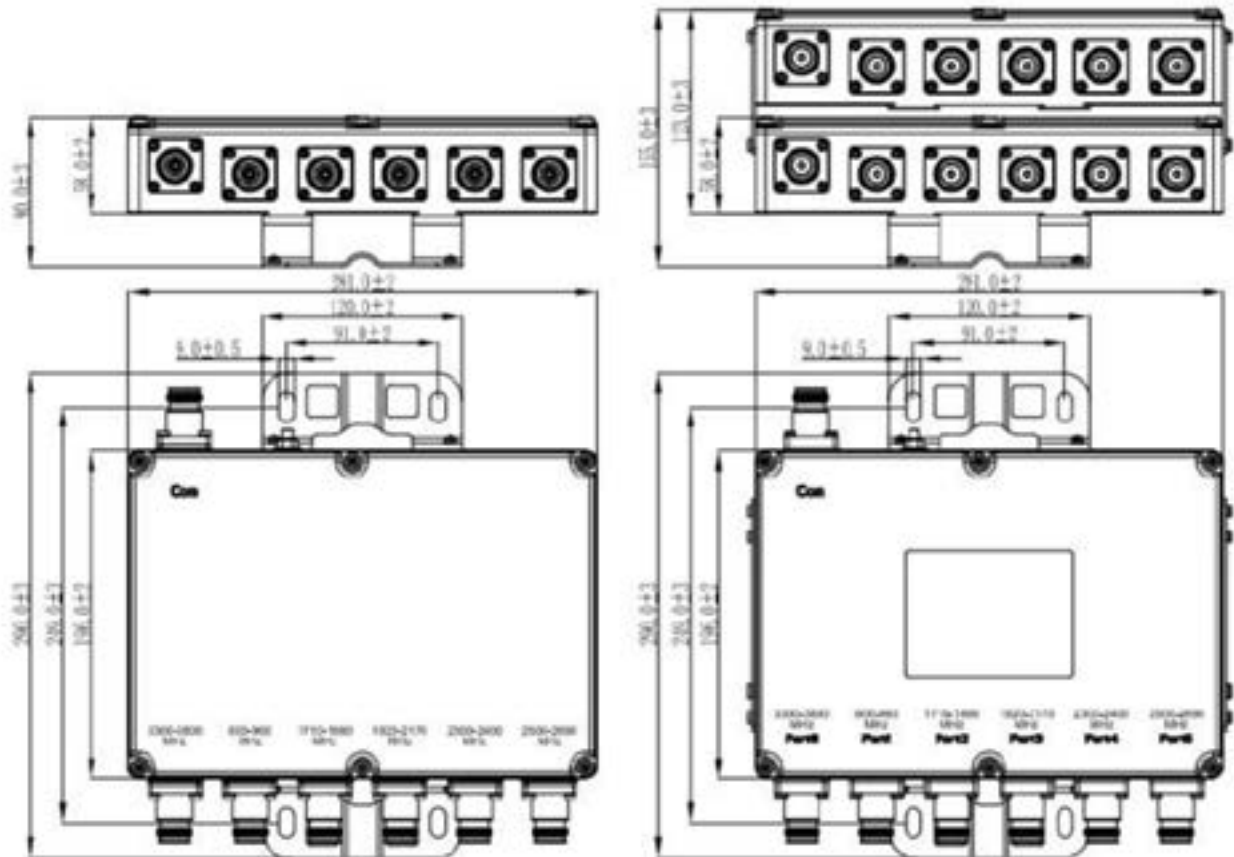

Trisector and Cannister antennas

Part Number	Description	Page
ECOSD1R2Y	Trisector 18 port antenna 1L2H (2000x365mm)	144
ECOSD4P	Trisector 24 port antenna 4P + 1 calibration per sector (1250x370mm)	146
ECOSC2Y2P	Pseudo omni canister antenna 1710-2690/3300-4200Mhz 9.4/9.2 dBi	148
ECOSC2Y2P/2S	Bidirectional cannister antenna 4T4R 1695-4200Mhz T2° 11dBi	150
801112006	Bidirectional cannister 4T4R 1695-4200Mhz T0° 9/10 dBi	152
801112007	Bidirectional cannister 4T4R 1695-4200Mhz T0° 11.5/12dBi	153
70010023	Wall mount stand for cannister 801112006	154

ECOSD1R2Y

**Tri-Sector with
Internal RET antenna**

2-port x 698-960 MHz
4-port x 1710-2690 MHz
H 65° / V 6.5°
Gain : 15 dBi / 17 dBi

Electrical specifications

Port Information	R1		
Frequency Range (Mhz)	698-806	790-862	880-960
Gain (Mid Tilt) (dBi)	15.3	15.4	15.1

Horizontal Pattern

Azimuth Beam width (°)	73		74
Front-to-Back Ratio (dB)	20	22	20
Cross Polar Discrimination at Boresight (dB)	17		

Vertical Pattern

Elevation Beam width (°)	11.5	10.5	10
First Upper Side Lobe Suppression (dB)	15		
Electrical Down tilt continuously adjustable (°)	2-12		

Electrical specifications

Port Information	Y1-Y2				
Frequency Range (Mhz)	1710-1880	1850-1990	1920-2170	2300-2400	2500-2690
Gain (Mid Tilt) (dBi)	16.2	16.6	16.8	16.7	16.7

Horizontal Pattern

Azimuth Beam width (°)	72	64	63	69	72
Front-to-Back Ratio (dB)	23	24	24	24	20
Cross Polar Discrimination at Boresight (dB)	18			15	15

Vertical Pattern

Elevation Beam width (°)	7.1	6.4	6.1	5.4	4.8
First Upper Side Lobe Suppression(dB)	15				
Electrical Down tilt continuously adjustable (°)	2-12				

General specifications

In-Band Cross Polar Port Isolation (dB)	>25
Inter-Band Port Isolation (dB)	>30
VSWR	1.5 : 1
Polarization	±45
Intermodulation IM3 (dBc)	-153(2 x 43 dBm Carrier)
Impedance (Ω)	50
Max. Effective Power per Port (Watts)	250

Mechanical specifications

Connector Type & Quantity	18 x 4.3-10 Female
Connector Position	Bottom
Lightning Protection	DC Ground
Antenna Dimension (D x H) (inch / mm)	Ø 14.3 x 78.7 / Ø 365 x 2000
Weight (without Mounting Kit) (lb / kg)	99.2 / 45
Wind Load (@100 mph) (N)	Front 970, Side 970
Max.Wind Speed (Survival Wind Speed) (mph)	150
Radome (Color)	FRP (Gray)

Remote Electrical Tilt (RET)

Internal RET	ACS-RM800(internal replaceable RET)
Protocol	3GPP/AISG 2.0

Array information



Array	Frequency(MHz)	Connectors
R1	698-960	1-2
Y1-Y2	1710-2690	3-6

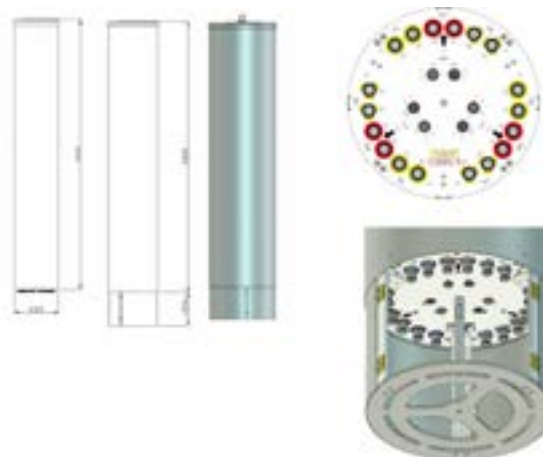

ECOSD4P

3.5G 8T8R Tri-Sector Antenna

(8-port x 3400-3800 MHz) x 3 sector
 H 70°, V 6.5°
 Gain : 15.0 dBi
 Electrical Down tilt : 2°-12°

Electrical specifications Service Beam (beamforming)	
Port information	P1-P4
Frequency Range (MHz)	3400-3800
0° Beam Gain (dBi)	19.2
+30° Beam Gain (dBi)	19.0
Horizontal Pattern	
0° Beam Azimuth Beam width (°)	23
0° Beam Front-to-Back Ratio (dB)	>23
0° Beam Cross Polar Discrimination at Boresight (dB)	>15
+30° Beam Azimuth Beam width (°)	24
+30° Beam Front-to-Back Ratio (dB)	>23
+30° Beam Cross Polar Discrimination at Boresight (dB)	>15
Vertical Pattern	
0° Beam Elevation Beam width (°)	7
0° Beam First Upper Side Lobe Suppression	>13
+30° Beam Elevation Beam width	7
0° Beam First Upper Side Lobe Suppression	>13
Electrical Downtilt continuously Adjustable	2-12

Electrical specifications Single Column Beam	
Port information	P1-P4
Frequency Range (MHz)	3400-3800
Gain (dB)	14.5
Horizontal Pattern	
Azimuth Beam width (°)	80
Front-to-Back Ratio (dB)	>21
Cross Polar Discrimination at Boresight (dB)	>15
Cross Polar Discrimination over Sector (dB)	>8
Vertical Pattern	
Elevation Beam width (°)	7
Electrical Downtilt continuously Adjustable (°)	2-12
First Upper Side Lobe Suppression (dB)	>13

Electrical specifications Broadcast Beam (beamforming)	
Port information	P1-P4
Frequency Range (MHz)	3400-3800
Gain (dB)	15.5
Horizontal Pattern	
Azimuth Beam width (°)	65
Front-to-Back Ratio (dB)	>21
Cross Polar Discrimination at Boresight (dB)	>15
Vertical Pattern	
Elevation Beam width (°)	7
Electrical Downtilt continuously Adjustable (°)	2-12
First Upper Side Lobe Suppression (dB)	>13

General specifications

Intraband Isolation (dB)	>25
Interband Isolation (dB)	>20(P1//P2//P3//P4)
VSWR	1.5 : 1
Polarization	±45
Intermodulation IM3 (dBc)	-153(3rd order, 2x20W)
Impedance (Ω)	50
Max. Effective Power per Port (Watts)	75

Mechanical specifications

Connector Type & Quantity	27 x 4.3-10 Female 8+1 (calibration port) per sector
Connector Position	Bottom
Antenna Dimension (D x H) (inch / mm)	39.4 x Ø 14.5 / 1000 x Ø370
Weight (without Mounting Kit) (lb / kg)	50.7 / 25
Wind Load (@100 mph) (N)	330
Max.Wind Speed (Survival Wind Speed) (mph)	150
Radome (Color)	ASA (Light Gray)

Array information

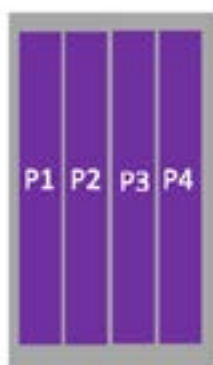

Array	Frequency(MHz)	AISG RET Unique ID	Connectors
P1-P4	3400-3800	GNRETXXXXXXXXXX XX3	27 x 4.3-10 Female 8+1 (calibration port) per sector

Outline

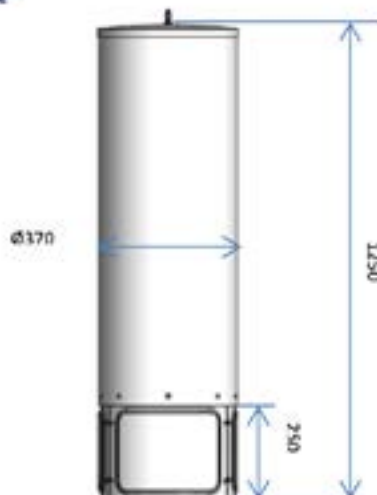

ECOSC2Y2P

Small Cell Pseudo Omni Canister Fixed Antenna

4-port x 1710-2690 MHz
 4-port x 3300-4200 MHz
 HPBW: 360°
 Gain: 9.4 dBi, 9.2 dBi

Electrical specifications

Port Information	Y1-Y2				P1-P2
Frequency Range (Mhz)	1710-1850	1850-1910	1910-2180	2300-2690	3300-4200
Gain Max (dBi)	9.4	9.1	9.3	9.4	9.2
Gain Avg (dBi)	8.9	8.8	8.8	9	8.5

Horizontal Pattern

Azimuth Beam width (°)	360				
GainOMNI Deviation (dB)	3.5	5	5	5	6

Vertical Pattern

Elevation Beam width (°)	16	16	15	14	15
First Upper Side Lobe Suppression(dB)	11				8

General specifications

In-Band Cross Polar Port Isolation (dB)	>20				
Inter-Band Port Isolation (dB)	>25				
VSWR	1.5 : 1				
Polarization	±45°				
Intermodulation IM3 (dBc)	-153 (3rd Order, 2x20W)				-
Impedance (Ω)	50				
Max. Effective Power per Port (Watts)	100				

Array information

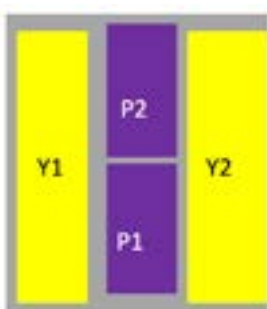

Array	Frequency(MHz)	Connectors
Y1-Y2	1710-2690	1-4
P1-P2	3300-4200	5-8

Outline



Bottom



Bracket

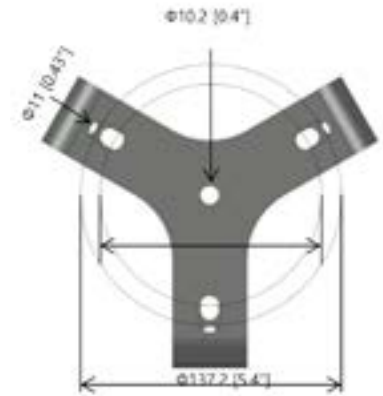
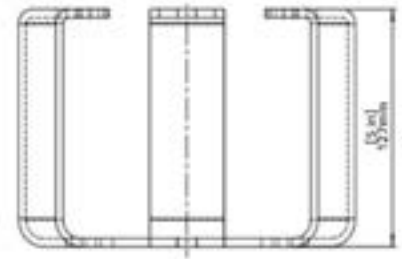

Mechanical specifications

Connector Type & Quantity	8 x 4.3-10 Female
Connector Position	Bottom
Antenna Dimension (WxD) (inch / mm)	$\phi 9.4 \times 23.6 / \phi 240 \times 600$
Weight (without Mounting Kit) (lb/kg)	22.15 / 10.05
Wind Load (@100 mph) (N)	230
Max.Wind Speed (Survival Wind Speed) (mph)	150
Radome (Color)	ASA (Gray)

Pattern File_1700-2000 MHz

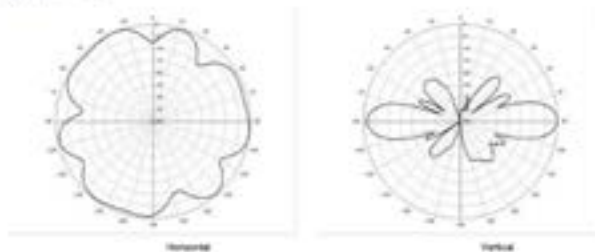

Pattern File_1300-4200 MHz

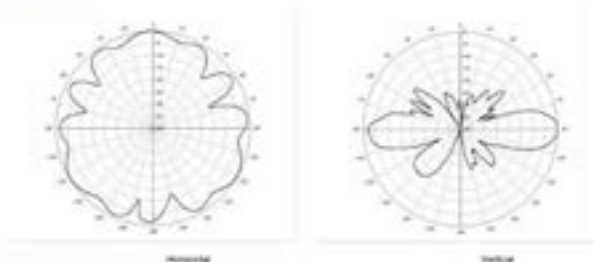

ECOSC2Y2P/2S

BIDIRECTIONAL Small Cell Canister Antenna

4-port x 1695-2700 MHz
 4-port x 3300-4200 MHz
 HPBW : 70°, 70°
 Gain : 11.8 dBi, 10.9 dBi

Electrical specifications

Port Information	Y1-Y2			
Frequency Range (Mhz)	1695-1920	1920-2180	2305-2360	2360-2700
Gain Max. (dBi)	9.6	11.3	11.5	11.8
Gain Avg. (dBi)	8.6	8.8	10.4	10.2
Horizontal Pattern				
Azimuth Beam width (°)	94	73	62	62
Vertical Pattern				
Elevation Beam width (°)	17	15	13	12
First Upper Side Lobe Suppression (dBi)	13	13	13	13
Electrical Down Tilt	Fixed 2°			

Electrical specifications

Port Information	P1-P2		
Frequency Range (Mhz)	3300-3550	3550-3700	3700-4200
Gain Max. (dBi)	9.3	9.7	10.9
Gain Avg. (dBi)	8.3	9.2	9.9
Horizontal Pattern			
Azimuth Beam width (°)	80	70	61
Vertical Pattern			
Elevation Beam width (°)	16	16.1	13.8
First Upper Side Lobe Suppression (dBi)	13	13	13
Electrical Down Tilt	Fixed 2°		



General specifications

Port information	Y1-Y2	P1-P2
Isolation (dB)	>20	
VSWR	1.5 : 1	
Polarization	±45	
Intermodulation IM3 (dBc)	-153(3rd Order, 2x20W)	-
Impedance (Ω)	50	
Max. Effective Power per Port (Watts)	100	

Mechanical specifications

Connector Type & Quantity	8 x 4.3-10 Female
Connector Position	Bottom
Antenna Dimension (D x H) (inch / mm)	\varnothing 7.9 x 23.6 / \varnothing 200 x 600
Weight (without Mounting Kit) (lb / kg)	11 / 5
Wind Load (@100 mph) (N)	107
Max.Wind Speed (Survival Wind Speed) (mph)	150
Radome (Color)	ASA (Light Gray)

Array information

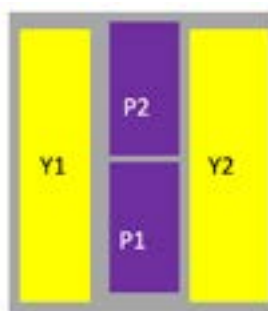

Array	Frequency(MHz)	Connectors
Y1-Y2	1965-2700	1-4
P1-P2	3300-4200	5-8

Outline

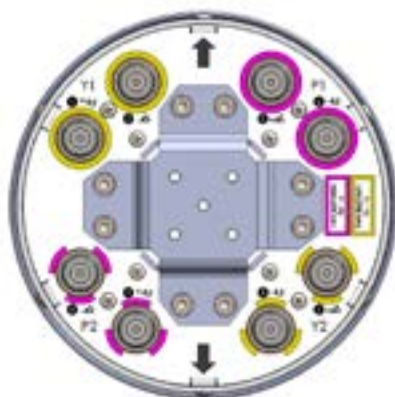
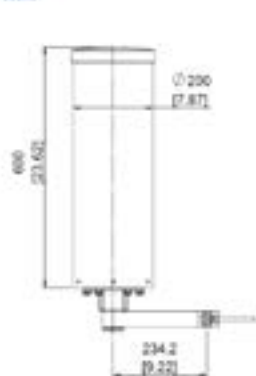

Pattern File_1965-2700 MHz

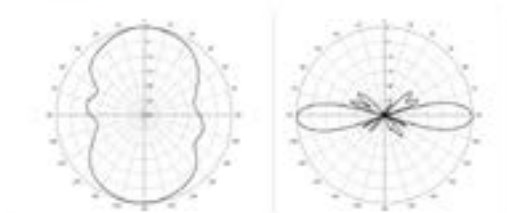

Pattern File_3300-4200 MHz

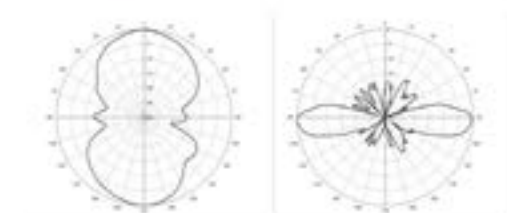

8011120006

BIDIRECTIONAL 4T4R Small Cell Canister Antenna

XXPOL 4Port
1695-2700 MHz / 3300-4200 MHz
HPBW : 68 °, 65 °
Gain : 9 dBi, 10 dBi

Type	8011120006	
Frequency Range (MHz)	1695-2700	3300-4200
Gain (dBi)	9.0	10.0
VSWR	≤ 1.7	≤ 1.8
Polarization	±45°	
PIM3 (dBc, @2x43dBm)	≤ -150	N/A
Isolation (dB)	≥ 22	≥ 22
Horizontal Beamwidth (°)	68	65
Vertical Beamwidth (°)	34	34
Input Impedance (ohm)	50	
Max. Input Power (W)	100	
Lightning Protection	DC Grounded	
Connector	4 x 4.3-10 Female	
Dimension (mm)	280 x 450	
Weight (kgs)	Approx. 10kg antenna and 7kg bracket	
Radome Material	UPVC white	
Max wind velocity	200Km/h	
Wind load (N, @150Km/h)	143.52	
Operating Temperature (°C)	-40 to +65	
Mounting	Pole mount bracket included Ø50- Ø80mm	
Optional accesory (*order separately)	Wall mount stand 70010023	

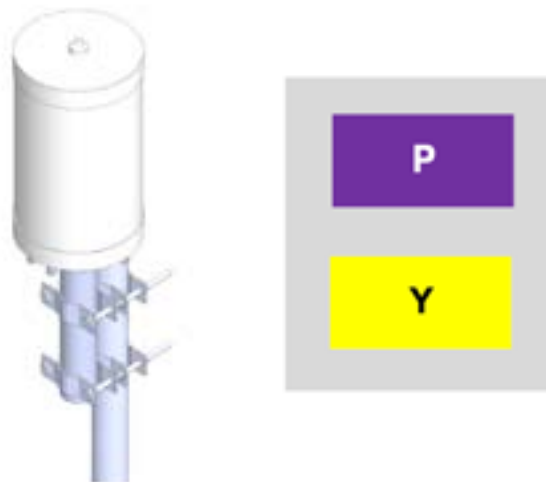

801112007

BIDIRECTIONAL 4T4R Small Cell Canister Antenna

XXPOL 4Port
1695-2700 MHz / 3300-4200 MHz
HPBW : 39 °, 47 °
Gain : 12 dBi, 12 dBi

Type	801112007	
Frequency Range (MHz)	1695-2700	3300-4200
Gain (dBi)	12.0	12.0
VSWR	≤ 1.7	≤ 1.8
Polarization	±45°	
PIM3 (dBc, @2x43dBm)	≤ -150	N/A
Isolation (dB)	≥ 22	≥ 22
Horizontal Beamwidth (°)	39	47
Vertical Beamwidth (°)	14	12
Input Impedance (ohm)	50	
Max. Input Power (W)	100	
Lightning Protection	DC Grounded	
Connector	4 x 4.3-10 Female	
Dimension (mm)	280 x 900	
Weight (kgs)	Approx. 12kg antenna and 8kg bracket	
Radome Material	UPVC white	
Max wind velocity	200Km/h	
Wind load (N, @150Km/h)	143.52	
Operating Temperature (°C)	-40 to +65	
Mounting	Pole mount bracket included Ø50- Ø80mm	

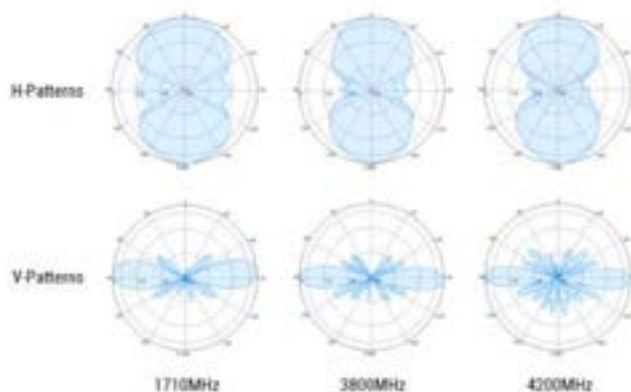

70010023

For Tri-Sector / Quasi Omni Antenna
(Ø280 x 450)

Wall Mount Stand

Type	70010023
Application	WallMountStandforwall-mountapplicationof quasi-omni / tri-sector / dual sector antennas Ø Antennasize:Ø280x450mm
Material	Hot dip galvanized steel
Size (reference only)	80 x 283 x 270mm
Accessories	4 sets of M12 x 80 Expansion Bolt, Nut and Washers (in 304 Stainless Steel)

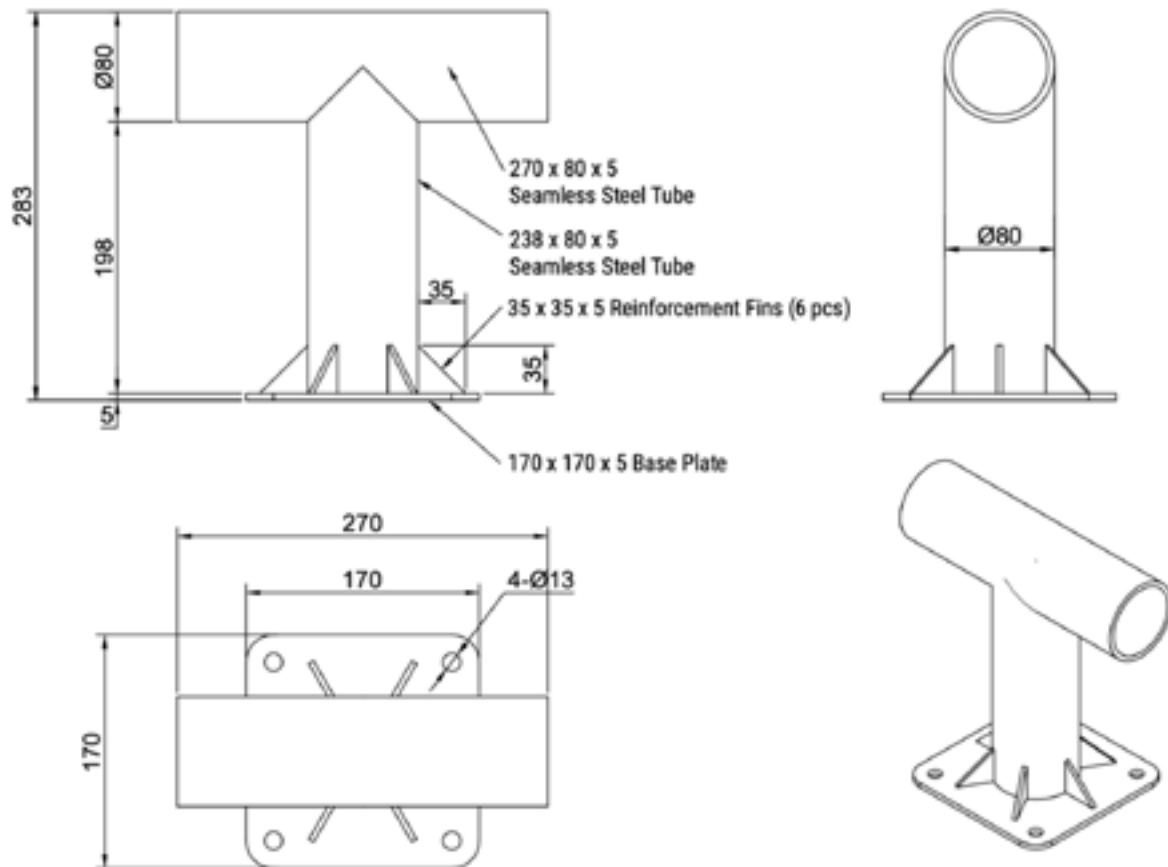

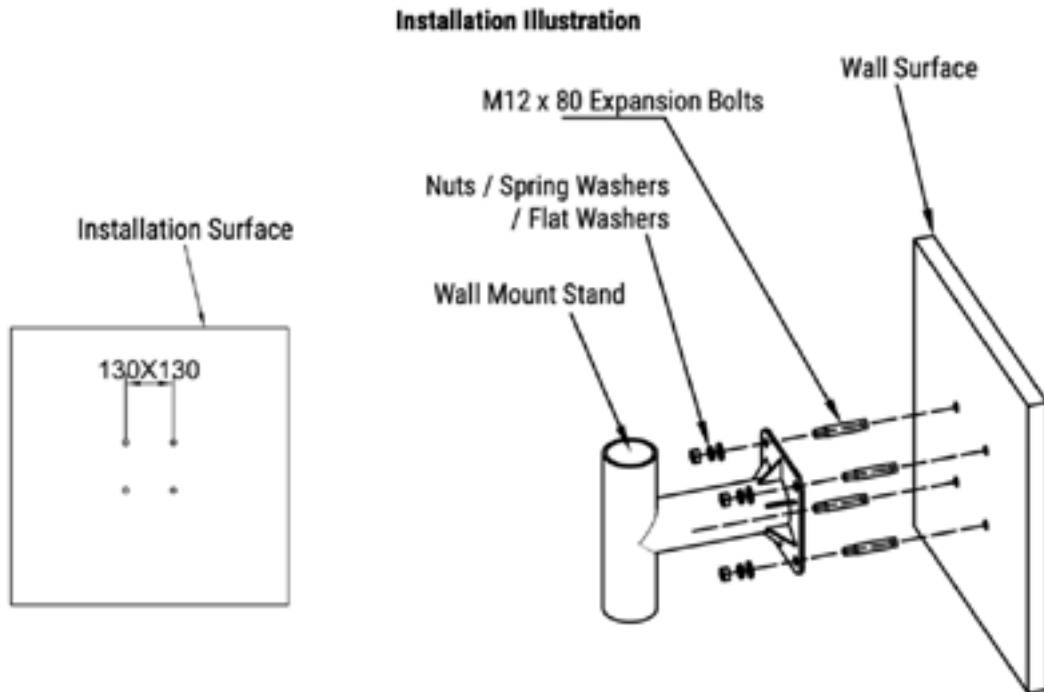

Assembly of Antenna and Wall Mount Stand
(Antenna Shown is Optional Item and Not Included in the Stand)

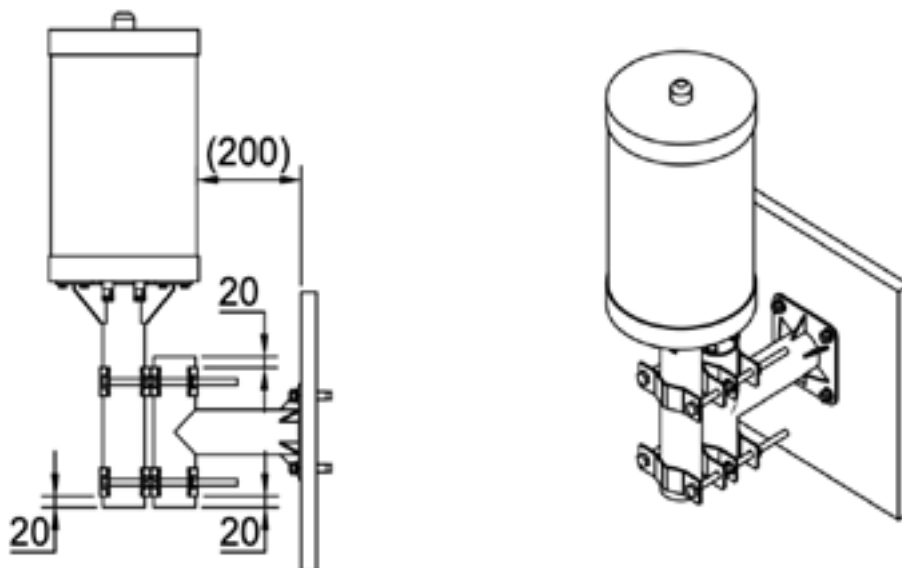

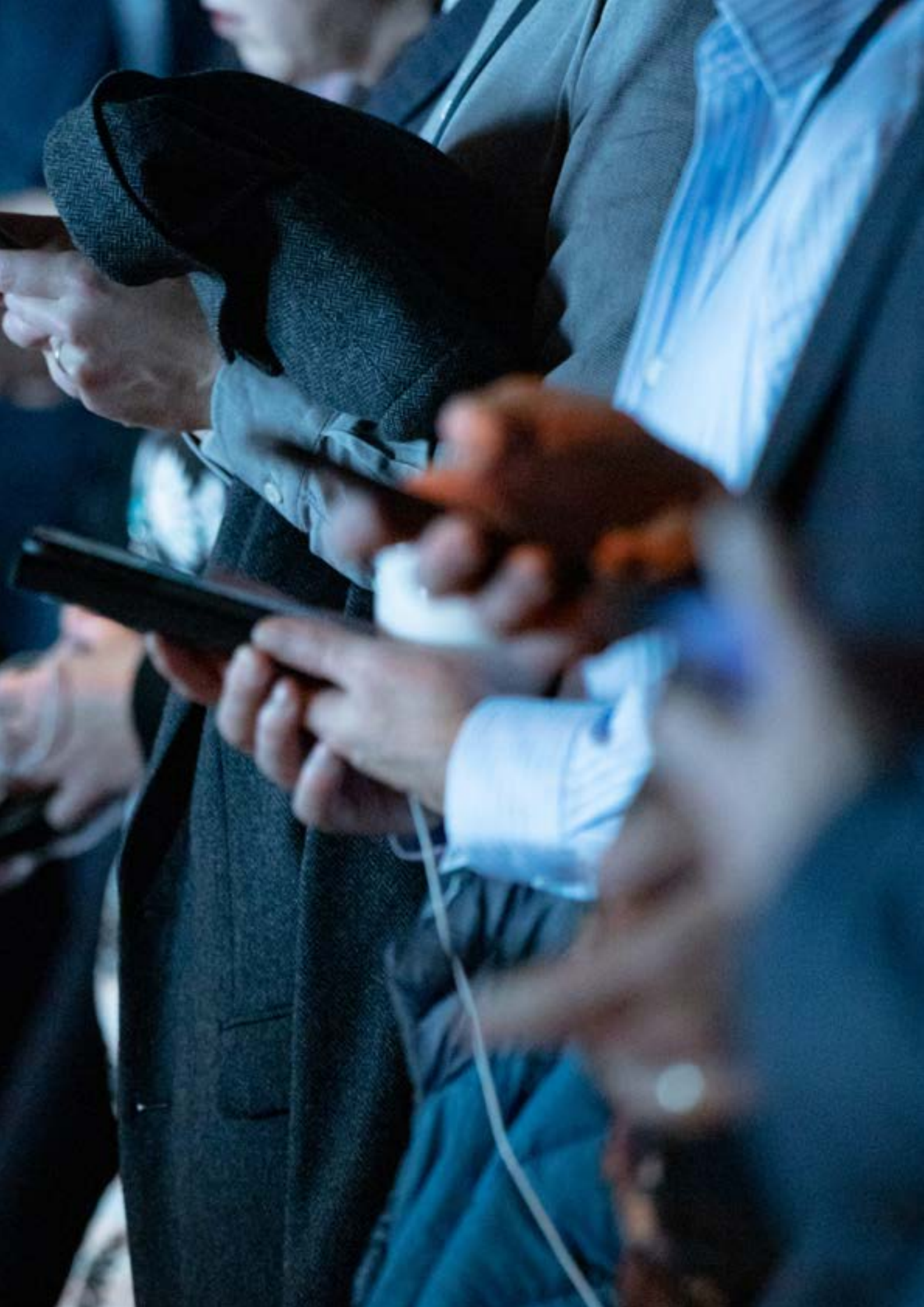



Shaping the
connected world